

General Catalogue

2014



Professional Audio for your world

pas 
SOUND SYSTEM SPECIALIST

Voice evacuation systems
Multizone voice/music systems
Interphone system for counters

Page 6



Mixer Amplifiers
Booster units

Page 28



CMDS Compact Music Distribution Systems
Sound sources
Mixer

Page 38



Microphones
Microphone bases
Wireless microphones

Page 46



Speaker units

Page 52





Historical origins ...

PASO SpA is an industrial company established in 1973 as the result of the enthusiastic work of the managerial and technical staff previously employed by the historical Milan-based company GELOSO, active since 1931 and international leader on the market of professional sound-broadcasting. PASO took over GELOSO's trademark, their patents and a valuable heritage of experience, skills and technical knowledge.

With roots firmly embedded in solid and prestige know-how, the company continued to increase its knowledge in the field of system and industrial engineering, with the primary aim of constant evolution of its Public Address products, in terms of technology, quality and reliability.

As a result of the company's experience with discussion and conference systems, in 2000 the trademark "AULA" was created to distinguish a line of top-of-the-range products for managing congresses.





... an important reality.

PASO SpA, a company of the FBT Group S.r.l., is now a leading company on the sound-broadcasting and congress system markets and is highly appreciated both in Italy and abroad.

The key issue of the company's policy is customer satisfaction, achieved by ensuring top-quality products and a top-quality service, pursued consistently and with enthusiasm, and supported by a catalogue of products able to meet all sorts of different needs as well as by a competent and professional sales department. All this is topped by the guarantee provided by the Quality System certified according to the latest version of UNI EN ISO 9001.

In the current global marketplace context, PASO SpA claims with well-justified pride its identity as an Italian manufacturing company that designs, develops, makes and markets its own products. Thanks to the commitment and professional skills of its personnel, the company has always remained in step with the technological evolution of both its products and its manufacturing activities, complying with the appropriate standards and directives that have succeeded each other in time.



PRODOTTI E SISTEMI PER
LA COMUNICAZIONE

Voice evacuation systems

Multizone voice/music systems

Interphone system for counters

PASO provides complete audio solutions for conventional sound-broadcasting systems and for systems applied to emergency able to manage alarm situations.



PA8500-VES

Voice Evacuation System



Enlarge your safety

Hospitals, schools, shopping centers, supermarkets, office buildings, sport centers...

On premises where large numbers of people are present it is essential to provide a suitable sound-broadcasting system that, following activation by the firefighting control unit, will handle the emergency situation and enable guided and controlled evacuation of the building.

Current standards define in detail the features of an electro-acoustic system for evacuation and emergency purposes in terms of design and installation so that it will meet the applicable safety and reliability requisites.

The Voice Evacuation **PASO** Systems are current answer to the needs specified in standards.

Flexible and easy installations

Design it with us!



PA8506-V Six zone integrated Voice Evacuation System



PASO, leader brand of “made in Italy” products is presenting the new range of products **PA8500-VES**. It has been designed and engineered to offer the most innovating solutions in the realization of alarms systems, in order to manage emergency situations and to permit the guided evacuation, according to actual regulations (**EN 54-16, ISO 7240-19 e EN 60849**).

The PA8500-VES offers the right answer for any system requirement; the combined action of the new control units and the new digital amplifiers permits flexible and easily expandable installations both for numbers of zones and for sound power, in compliance with safety standards.

The complete architecture of PA8500-VES system is based on the controller **CR8506-V**, the management and diagnostics unit. It is highly recommended for big as well as small installations, where high performance of security, flexibility and easiness are required. CAT5 network assures an easy connection of the several units, controllers, routers, digital amplifiers and emergency and/or paging call stations. This solution performs in efficient and economic installation, allowing the usage of both local and centralized equipment.

Each CR8506-V can manage 6 lines to which the following units can be directly connected:

- **PMD** range of digital amplifiers, equipped with a diagnostics card (up to 16 per line)
- Router **RT8506-V** for up to 6 outputs zones with A & B speaker lines
- **PA8506-V** Integrated Voice Evacuation Systems with 6 zones

The remote consoles **PMB132/12-V** and **PMB132-V** are fully monitored, and allow greater operational and management flexibility for any service and/or emergency calls and/or prerecorded messages on the zones of the system.

The possibility to connect in daisy chain up to 6 controller CR8506-V and to manage up to 36 lines allows to realize up to 216 zones for voice evacuation/music.

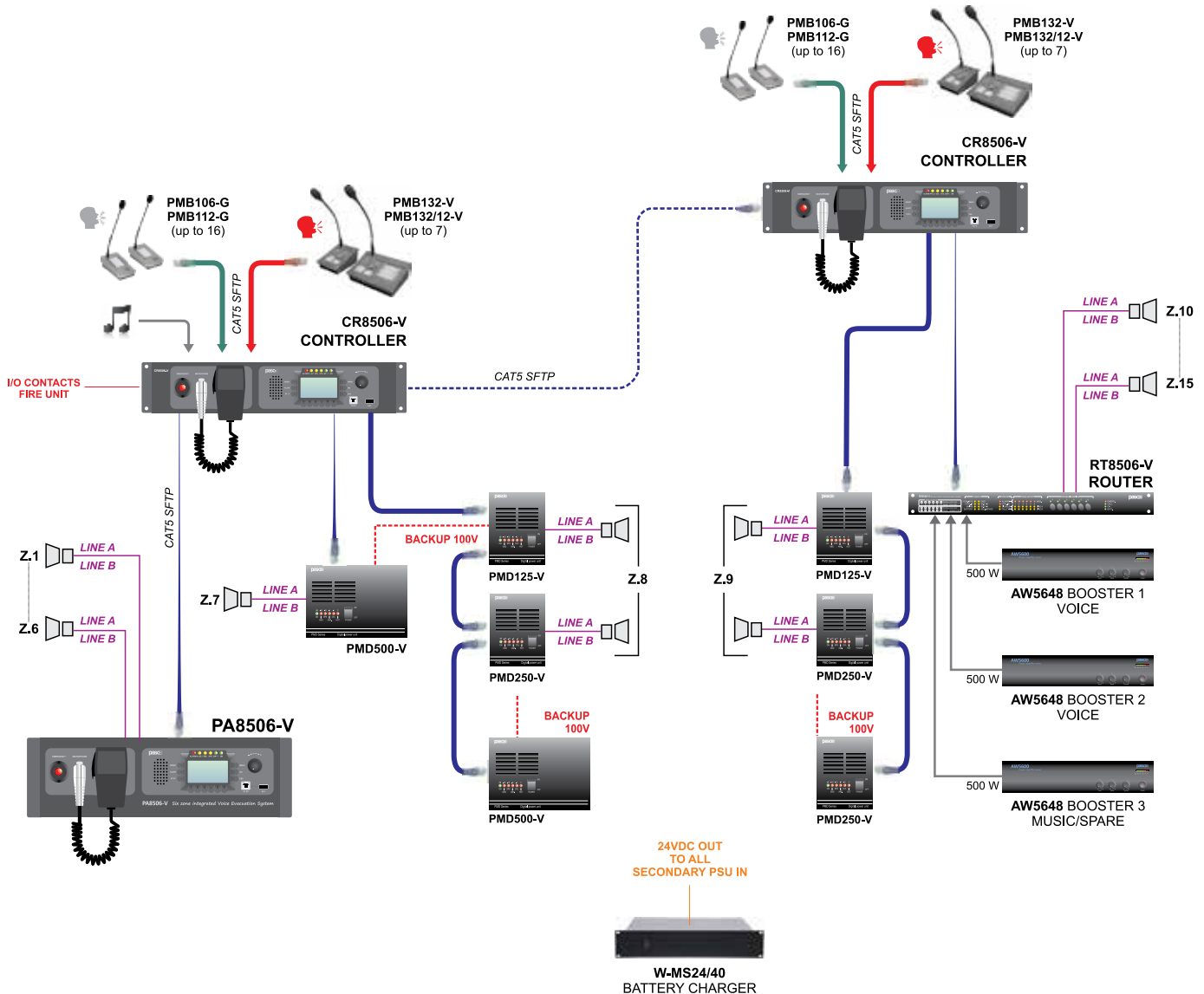



CR8506-V • Controller



CAT5 network assures an easy connection of the several units:

- 6 control lines for PMD digital amplifiers and/or router RT8506-V and/or integrated voice evacuation system PA8506-V
- 2 redundant lines to connect other CR8506-V in daisy chain (max 6)
- 2 redundant lines for emergency microphone consoles, PMB132 range (max 7)
- 2 lines for call stations PMB range (max 16 with 7 priority levels)

The controller **CR8506-V** is the heart of PA8500-VES evacuation system; it has been designed to drive all the supervising functions of the entire system, in compliance with the current safety standard for voice evacuation systems. It also manage and controls all the audio signals (evacuation, alert and standard messages and background music).

FUNCTIONAL FEATURES

- Controlled emergency microphone
- 2-channel broadcast system
- Built-in message generator to broadcast prerecorded messages (EVAC and ALERT)
- USB input for background music source
- Back-up power amplifier management
- Secondary emergency power supply input (24 VDC)
- 7 controlled input contacts
- 3 relay outputs
- Graphic display 128x64 pixel monochrome
- Complete diagnostic of system fault events
- Standard rack mounting 19" (2 units)



MODEL	CR8506-V
Inputs	
USB-EXT.	USB input powered via the front panel -Type A socket
Emergency microphone	Balanced XLR-F on front panel
IN1 MIC (Programmable modes: ON / OFF / Precedence / VOX)	Balanced XLR-F (with activatable 21 V phantom power supply)
IN2 (Programmable modes: ON / OFF / Precedence / VOX)	MIC: Balanced XLR-F (with activatable 21 V phantom power supply); LINE: Balanced with terminals (HOT-COM-GND)
AUX	RCA stereo socket for source of sound (BGM)
Paging units (2 lines)	2 RJ45 sockets per unit (PA) - PMB106-G, PMB112-G and ACIO8136
EMERGENCY UNITS (2 lines)	4RJ45 for connection and dedicated emergency microphone station (PMB132 range)
Outputs	
SLAVE LINK OUTPUT (6 lines)	6 RJ45 RT8506-V / PMD / PA8506-V unit connections
CR8506-V LINK (2 lines)	4 RJ45 CR8506-V redundant connections
Emergency controls	7 inputs with diagnostics (RJ45) and 3 relays for signalling emergencies and failures, N.O.-N.C. terminals
General informations	
Mains power supply, consumption	230 Vac 50/60 Hz, 10 W
Vdc secondary power supply, consumption	24 Vdc (min 22Vdc ÷ max 28Vdc), 0,3 A
19" rack mounting (modular units)	Direct (2U)
Dimensions (W x H x D)	482 x 88 x 220 mm
Weight	4 kg

PMD range • Class "D" modular amplifiers



PMD500-V



PMD125-V

PMD250-V

Careful design and a choice of very reliable hi-tech components led to the creation of this range of Class D amplifiers, featuring an extremely compact size and low energy consumption. Each has its own diagnostics card for testing correct operation and checking soundness of the loudspeaker line and a double output circuit with separate controls (A and B) for creating systems featuring line redundancy; if a short circuit is detected on one of the two outputs, this line is automatically disconnected to enable proper operation of the other. These modular amplifiers require a PMS2001 card-cage for mounting on a 19" rack. **PMD** amplifiers, connected directly to the CR8506-V controller by means of CAT5 shielded cable, can be used to create high-power areas. It is possible to connect up to 16 PMD units in cascade fashion to each of the six output lines (zones) of the CR8506-V. It is possible to configure one amplifier in each group as a stand-by unit. The fact that each amplifier is powered independently makes the system extremely reliable and in line with safety standards.

SPECIAL APPLICATIONS

PMD amplifiers can also be used without a PA8500-VES system whenever small layout dimensions combined with great reliability are required.

They can be controlled by means of configuring dip-switches on the rear of each unit or by means of a simple RS485 communication protocol, with complete supervision of the loudspeaker line connected to them. The communication protocol is compatible with the PMS2000-VES modular system. In addition to all the operations and/or checks set locally by means of the dip-switches, it will also be possible to view and modify all the parameters, including the following:

- reading of the reference impedance for the test
- minimum and maximum values within which the test is applicable
- reading of the test status
- testing of inputs
- measurement of the temperature of the end transistors
- volume control

FUNCTIONAL FEATURES

General features

- Operation on 230 VAC and 24 VDC
- Both stand-alone and remote-controlled operation are possible
- Double RJ45 input socket (for connecting more than one amplifier in parallel)
- Two audio inputs
- Front-panel LEDs indicating the output level or the operational status of the amplifier
- Forced fan cooling with an electronic control and protection circuit
- Output terminal block of the removable bayonet type

Local controls or via serial communication

- Output volume control
- Selection of the amplifier input
- Activation of the low-cut filter

Diagnostics

- Diagnostics of the main functions of the amplifier
- Checking and measurement of the impedance of the loudspeaker line (A and B)
- Check and exclusion of short-circuited loudspeaker lines
- Check of earth connections (GND FAULT)

PROTECTION DEVICES

In addition to conventional protection in the form of fuses, these amplifiers have electronic protection devices and circuit-breakers with automatic resetting, protecting them from the possible risk of damage due to overloads.

The front-panel LEDs have a dual function as VU Meter (in normal conditions) and for indicating the types of any failures detected by the control card.



CONNECTIONS

There are two RJ45 sockets on the rear panel of the unit. Their connections are in parallel with one another to enable audio connections at line level and for serial communication.

There is a removable bayonet-type terminal block for connection to the loudspeaker lines and, if required, to a stand-by amplifier.

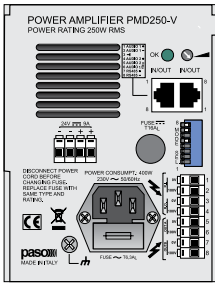

PMD125-V

PMD250-V

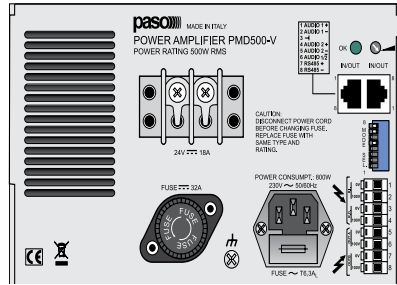

PMD500-V

RJ45 input

Pin	Description
1	Audio 1+
2	Audio 1-
3	GND
4	Audio 2+
5	Audio 2-
6	Audio switch
7	RS485 serial +
8	RS485 serial -
Shield	GND

Audio Input 1 and 2 are balanced electronically. All the connectors must be shielded RJ45 connectors.

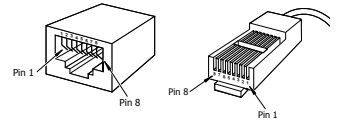

Power output

Pin	Description
1	Stand-by Bus IN (0 V)
2	Stand-by IN (100 V)
3	Stand-by OUT (0 V)
4	Stand-by OUT (100 V)
5	Output A (0 V)
6	Output A (100 V)
7	Output B (0 V)
8	Output B (100 V)

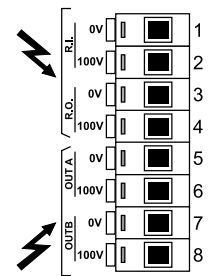

RACK-MOUNTING WITH A PMS2001 CARD CAGE

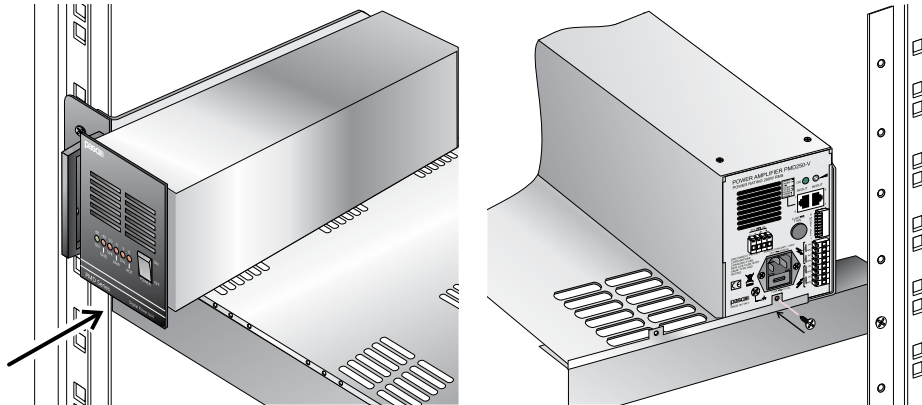

To install **PMD** amplifiers on 19" racks it is necessary to use the card-cage provided for this purpose. PMD amplifiers differ from one another only in terms of output power and size (two 125-W or 250-W amplifiers occupy the same space as one 500-W amplifier). Each PMS2001 card-cage can contain two 500-V amplifiers or four PMD125-V or PMD250-V amplifiers, or any intermediate configuration.

MODEL	PMD125-V	PMD250-V	PMD500-V
Nominal output power @230 Vac / 27 Vdc	125 W RMS	250 W RMS	500 W RMS
Power outputs		100 V (A and B lines)	
Distorsion at rated power		< 0,05 %	
Inputs	2 x RJ45, In/Out - 2 audio inputs (770 mV) and RS485 data		
Frequency response	90-20.000 Hz		
Low Cut filter (- 3 dB)	330 Hz		
Mains power supply	230 Vac ± 10% - 50/60 Hz / 24 Vdc		
Power consumption at 230 Vac	195 W	410 W	740 W
Current consumption at 24 Vdc	4,4 A	7,6 A	16,3 A
Consumption with no signal at 230 Vac / 24 Vdc	14 W / 0,14 A	15 W / 0,2 A	16 W / 0,25 A
19" rack mounting	Optional PMS2001 card cage (H: 3U + 1U support brackets)		
Mounting units to each PMS2001	4		2
Dimensions (W x H x D)	100 x 130 x 395 mm		200 x 130 x 395 mm
Weight	8,4 kg	9,2 kg	14,8 kg



The router **RT8506-V** is the best solution for the sound systems with a very interesting compromise between price and performance; connected to a CR8506-V control line, it can drive up to 6 zones with external power amplifiers (AW5600 range) to a maximum of 1000 W.

Each output line consists of 2 speaker circuits (A & B) in order to guarantee the complete area coverage also in case of one loudspeaker circuit failure. The maximum system configuration includes 6 controllers connected to 36 routers (6 for each CR8506-V) for a total of 216 zones.

The router can be used with power signals (amplifier 100 V output). Two different configurations are possible: in the first one you can connect 2 amplifiers (one for music and one for speech); in the second one it is possible to manage 2 voice amplifiers (3 zones each) and one music amplifier.

In any case all amplifiers are constantly monitored and the music one can be also used as backup: in case of a failure it automatically replaces the voice amplifier.

FUNCTIONAL FEATURES

- 6 loudspeakers zones with double output lines A+B
- Double input 100 V for 1 or 2 voice amplifiers (IN 1 zone 1÷3, IN 2 zone 4÷6)
- 100 V input for music/stand-by amplifier
- Front panel push button to switch on/off the music on each single zone
- RJ45 socket for CR8506-V connection
- 7 controlled input contacts
- 6 open collector outputs
- 2 relay outputs
- Standard rack mounting 19" (1 unit)

AW5600 RANGE AMPLIFIERS

With the RT8506-V router it is possible to use the certified AW5600 range boosters. Two models are available: one with an output of 240 W (**AW5624**) and the other with an output of 480 W (**AW5648**). The amplifiers of the AW5600 range are the ideal products for emergency systems. There is a specific switch on the rear panel for disabling all the front-panel controls (tone and volume controls), preventing accidental changes to the levels set during commissioning.



MODEL	RT8506-V
Mains power supply	230 Vac 50/60 Hz
Consumption @230Vac	12 W
Vdc secondary power supply	24 Vdc
Consumption @24Vdc	0,5 A
Maximum power switchable for single zone	500 W
19" rack mounting (modular units)	Direct 19" (1U)
Dimensions (W x H x D)	482 x 44 x 220 mm
Weight	4 Kg



CR8506-V Controller and Digital Amplifier PMD Series

It is possible to connect 6 controllers CR8506-V to each other and to manage up to a maximum of 36 groups of PMD digital amplifiers, obtaining a 2 channel system with 36 output zones with double line.

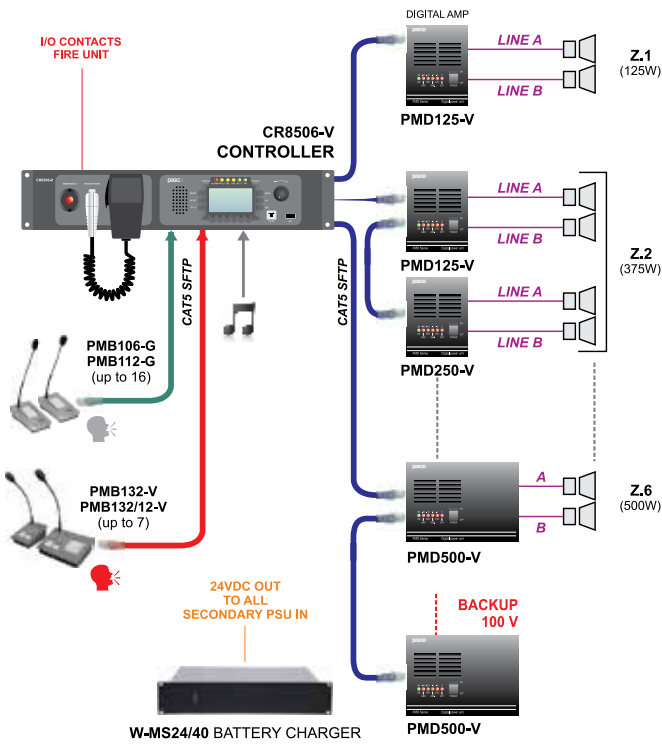

CR8506-V Controller and RT8506-V Router

In a system which includes 6 controller CR8506-V, each one connected to a maximum of 6 routers RT8506-V, it is possible to obtain up to 216 double line output zones.

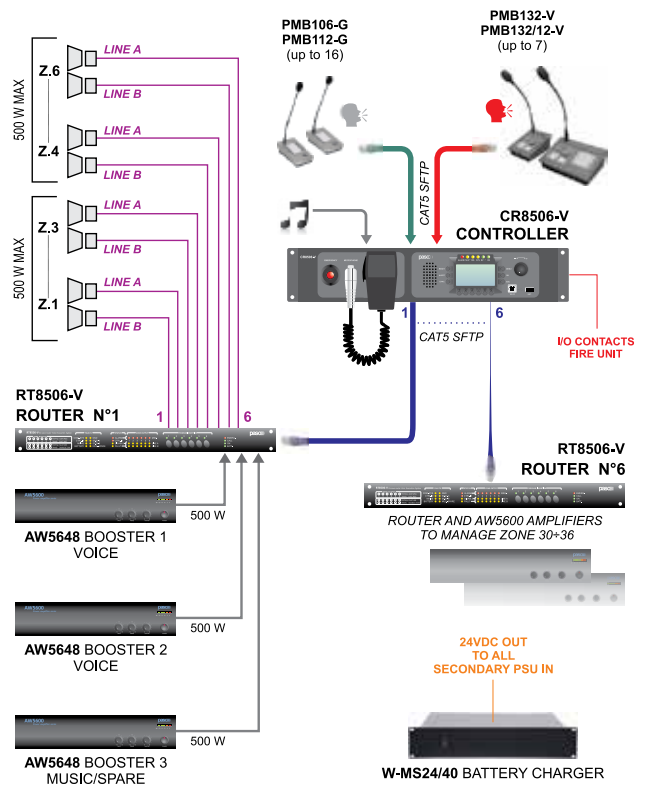

PA8500-VES • Solution with a Mixed Configuration

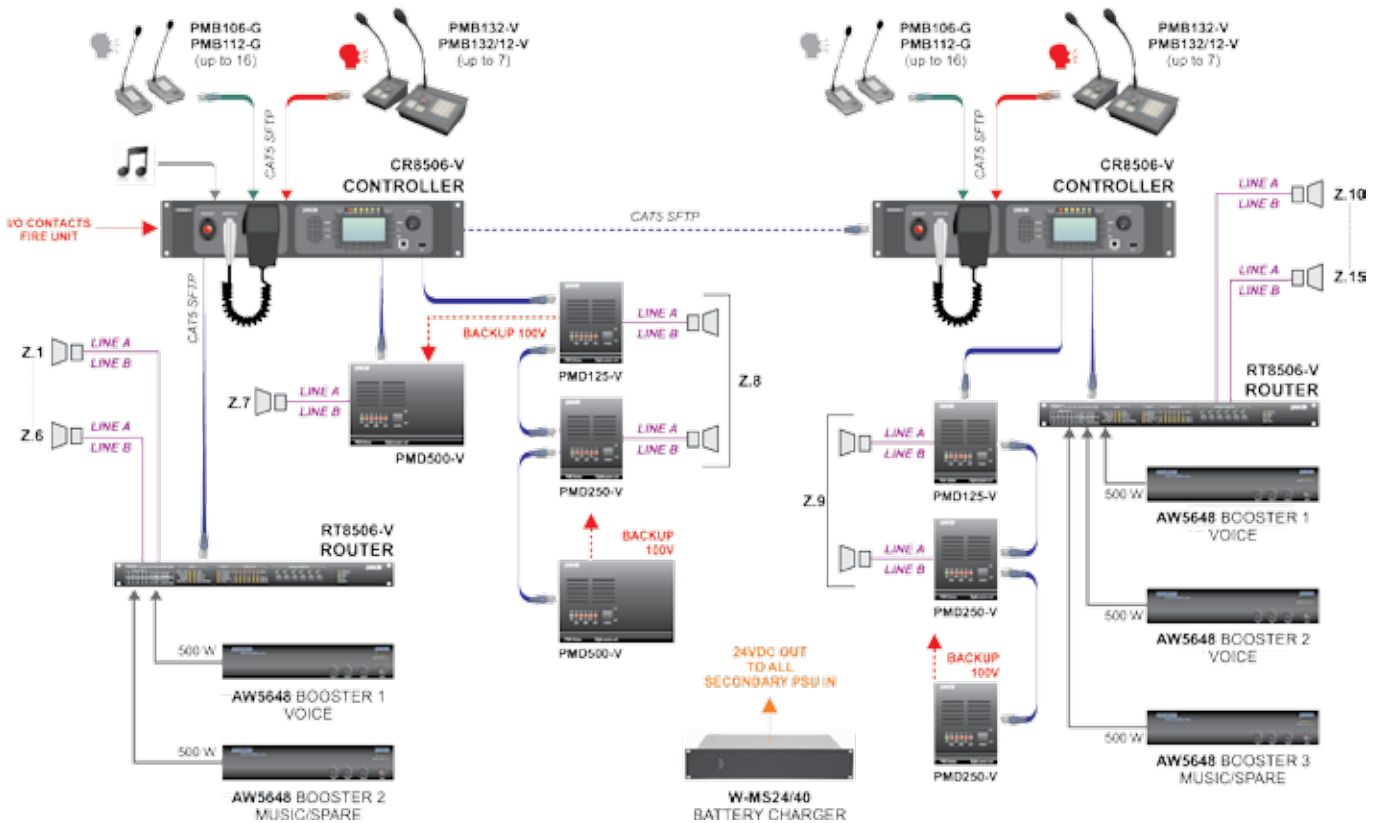

PA8500-VES Voice Evacuation System

PA8506-V • Integrated Voice Evacuation System



MAIN SYSTEM FEATURES

- EN 54-16: 2008 certified (n. **0068-CPD-081/2011**)
- ISO 7240-19 and EN 60849 compliance
- All in one Message/alarm generator, paging, BGM
- Two channel broadcast system
- Up to 12 output zones (using 2 PA8506-V units)
- Music volume control for each zone
- 1000 W maximum total power (complete configuration, 2 PA8506-V units and 2 AW5624 external amplifiers)
- Full digital audio control (DSP)

The **PA8506-V** is a **PASO** sound management system, which integrates emergency and general purpose broadcast functions. It enables background music and general or zone calls without interfering with its diagnostic routine. It's designed for easy installation and operation in a wide range of applications where both emergency voice alarm systems and public address systems are required, always according to the voice evacuation safety standards.

It can be possible to connect easily (by simple CAT 5 cable) two main PA8506-V to create systems of up to 12 zones, for a maximum of 1000W and connect up to 14 emergency microphone units (thanks to the PMB132 series). The PA8506-V has all the functional features normally provided by more expensive systems, and it is therefore characterized by an exceptionally favourable price/performance ratio. It includes an emergency microphone, two class D power amplifiers, a message generator and BGM USB input. It provides also 6 zone outputs, with continuous speaker line monitoring function.

The speaker output section consists of 6 separated lines; each line has its own internal music level control. Furthermore, each output line consists of 2 speaker circuits (A & B) in order to guarantee the complete area coverage also in case of one loudspeaker circuit failure. The front controls and the LCD display allow easy system setup.

Other than paging and music broadcast operations, the PA8506-V is able to make alarm announcements in emergency situations. According to EN54-16 standard, the built in surveillance function continuously checks the system for all possible failures. The equipment is a fully 2-channel broadcast system including 2-built in class D amplifiers (2 x 250 W RMS, one for music and one for speech). Both amplifiers are continuously monitored. The music amplifier operates also as stand-by amplifier: in case of speech amplifier failure, the music amplifier automatically replaces it.

The PA8506-V can be mounted in a 19" standard rack (3-unit height).





PA8506-V • TECHNICAL FEATURES

- Two built-in 250 W RMS class D power amplifiers
- External 250 W amplifier to increase power (AW5624)
- Up to 7 remote emergency microphone units (SFTP CAT5 cable)
- Up to 16 paging units, 7 priority levels (SFTP CAT5 cable)
- Balanced microphone input (IN 1) with Phantom power supply and priority contact
- Balanced microphone or line input (IN 2) with Phantom power supply (MIC), priority contact or automatic precedence (VOX)
- Balanced line input (IN 3) with automatic precedence (VOX)
- Auxiliary line input for an external music source
- USB input for background music source
- 6 open collector outputs (system status or override to by pass attenuators)
- 8 programmable and controlled input contacts
- 2 relay outputs for emergency and failure conditions
- Built-in loudspeaker for channel monitoring and acoustic failure signalling (beep)
- Graphic display 128x64 pixel monochrome, for displaying multiple windows management
- Multi-function keys and knob help to navigate through the menus
- Emergency zone disabling and Do Not Disturb functions (DND)

MAIN EMERGENCY FEATURES

- Frontal Fireman's microphone. It works only under Emergency Manual and has priority over pre recorded messages of an emergency. The microphone capsule is controlled by the internal diagnostic system
- Emergency button with LED (red) collected for the activation of the Emergency Manual mode. Allows access to the system, with absolute priority, from the "State of Quiet" or during the Emergency Automatic ongoing, previously activated by external devices
- Remote emergency microphones units, PMB132 series
- Control and monitoring of the integrity of the critical path (from the emergency signal sources to the loudspeaker lines)
- Continuous loudspeaker line monitoring (integrity and dispersion to earth) without interruption of BGM or paging calls
- Two output loudspeaker lines for each zone (A & B)
- Built-in message generator to broadcast prerecorded messages (EVAC and ALERT)
- Back-up power amplifier management (built-in unit)
- Complete diagnostic of system fault events
- Management of a secondary source of 24 Vdc power with a battery-charging unit

MODEL	PA8506-V			
Rated output power (230 Vac / 24 Vdc)	250 + 250 W RMS / 160 + 160 W RMS (dual voice and music channel)			
Inputs	IN 1	IN 2	IN 3	AUX
Type	Balanced XLR-F (with activatable 21 V phantom power supply)		Balanced with terminals (HOT-COM-GND)	Unbalanced RCA
Programmable mode	ON / OFF / PRECEDENCE / MIX IN2	ON / OFF / PRECEDENCE / VOX	ON / OFF / VOX	-
Sensitivity / Impedance	Min. 3 mV - Max 100 mV / 1,8 kΩ	MIC: Min. 3 mV - Max 100 mV / 1,8 kΩ LINE: Max 1800 mV / 31 kΩ	Max 3600 mV / 3 kΩ	Max 1800 mV / 31 kΩ
Frequency response / S/N ratio	240 ÷ 20.000 Hz / 63 dB	MIC: 240 ÷ 20.000 Hz / 63 dB LINE: 60 ÷ 20.000 Hz / 84 dB	90 ÷ 20.000 Hz / 86 dB	60 ÷ 20.000 Hz / 84 dB
Dedicated inputs	Emergency microphone, balanced XLR - Paging Units (PMB106-G, PMB112-G and ACIO8136), 2 RJ45 Emergency Units, RJ45 - USB-EXT., type A			
External amplifier input (EXT. AMP. IN)	Input with terminals 0-70-100 V (max 250 W RMS)			
Constant voltage outputs	6 zones for dual-line /A/B) 100 V lines – Tot. 12 pairs of terminals, 2,5 mm ²			
Load impedance	Min. 40W for total group of zones 1 to 6 with 250 W external amplifier: Min. 40W for total group of zones 1 to 3 / Min. 40W for total group of zones 4 to 6			
External amplifier output	Balanced XLR			
Sensitivity / Impedance	1 V / 500 Ω			
Frequency response / S/N ratio	40 ÷ 20.000 Hz / 84 dB			
Monitor BF OUT	Loudspeaker built into front panel 1 W / 8 W and rear output with terminals (HOT-GND) - 1 V / 400 W			
Emergency controls	Programmable to normally open or normally closed states			
Type	8 inputs with diagnostics. Terminals and service power supply: 24 Vdc (CONTROL INPUTS) 6 open-drain outputs, max 200mA. Terminals and service power supply: 24 Vdc (CONTROL OUTPUTS) 2 relays for signalling emergencies and failures, N.O-N.C. terminals			
Mains power supply	230 Vac 50/60 Hz			
Max consumption @ rated output power RMS	(500 W System) P = 650 W/800 VA - (250 W System) P = 370 W/480 VA			
Typical consumption with voice signal	(500 W System) P = 160 W/200 VA - (250 W System) P = 90 W/120 VA			
Consumption with no signal (test tone only)	P = 30 W/45 VA			
Vdc secondary power supply	24 Vdc (min 22 Vdc ÷ max 28 Vdc)			
Max consumption @24Vcc (@28Vcc)	500 W System = 17 A (21 A) - 250 W System = 9 A (11 A)			
Typical voice signal consumption @24Vcc (@28Vcc)	500 W System = 4,3 A (5 A) - 250 W System = 2,2 A (2,5 A)			
Consumption with no signal (test tone only)	0,8 A			
Operating environmental conditions	Temperature: +5°C to +40°C - Relative humidity: 25%-75% non-condensing			
19" rack mounting	Optional AC8506 brackets (height: 3U + 1U support brackets)			
Dimensions (W x H x D)	439 x 132 x 387 mm			
Weight	20,5 Kg			
			MICROPHONE BASES WITH ZONE SELECTION	
				
			To PA8506-V can be easily and quickly connected up to 16 microphone paging units (PMB106-G and PMB112-G) and up to 7 microphone emergency units PMB132-V and PMB132/12-V), which allow to send messages either to one or more zones. The usage of shielded cables CAT5e SF/UTP is needful.	

PMB132 range • Emergency Paging Units



FUNCTIONAL FEATURES

- Fully monitored
- Emergency key
- Live emergency calls
- Sending of pre-recorded Evacuation/Alert messages
- Broadcast calls
- Zone-selection keys with status-LEDs (PMB132/12-V only)
- Faults/Failures LEDs
- AUX function to call pre-set messages
- Reset of emergency messages
- Muting of the buzzer for failure detection (ACK)

The remote consoles PMB132/12-V and PMB132-V are fully monitored, and allow greater operational and management flexibility for any service and/or emergency calls and/or prerecorded messages on the zones of the system. The LEDs on the front panel provide the main information on the status of the emergency system and on any failures. The PMB132-V station enables a single All-Call to be made; if the alarm messages have to be sent to separate zones, on the other hand, it will be necessary to use the PMB132/12-V station, which enables a maximum of 12 zones to be selected. Each station must be completed with an additional microphone to be chosen from among the following models:

- MC132-V Dynamic gooseneck microphone
- M132-V Dynamic hand-held microphone with P.T.T. key

According to the used system units, it is possible to set-up the PTT and AUX keys and, only for the PMB132/12-V, each of the 12 selection keys in order to enable selection of groups of zones (keys 1 to 12 and the PTT key) or to create a specific combination of messages for the different zones (AUX key). It is possible to connect up to 7 remote station units in cascade formation by means of the IN/OUT sockets provided for this purpose, which can be used as inputs or outputs as required. The connections to the units are made by means of CAT5e SF/UTP shielded cable and a shielded STP connector.

CONNECTIONS

The connections to the PMB132 stations are made by means SF/UTP CAT5E shielded cable and RJ45 shielded connectors.

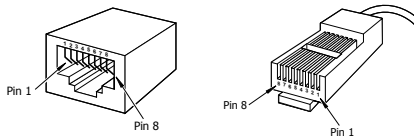

Pin	Description
1	Audio +
2	Audio -
3	GND
4	Not connected
5	Not connected
6	+ Vdc
7	Serial +
8	Serial -
Shield	GND

MODEL	PMB132-V	PMB132/12-V
N° of zone selectable	-	12
Typical output level	300 mV	
Frequency response	130 ÷ 19.000 Hz	
Distortion	< 1%	
LOW CUT filter	-3 dB / 380 Hz	
S/N ratio	> 60 dB	
Connections	RJ45 (IN/OUT)	
Power supply voltage	24 Vcc	
Maximum absorption @24Vdc	60 mA	130 mA
Dimensions (W x H x D)	140 x 80 x 200 mm	230 x 80 x 200 mm
Net weight	0,77 kg	1,55 Kg

Broadcasting Paging Units

Standard paging units can be used in the **PASO** Voice Evacuation Systems. The units are connected to one another in cascade formation, and the connecting cables (CAT5e SF/UTP) carry both the analogue audio signal and the digital signal for the controls and station addresses.

The **PMB106-G** call station can make selective calls to up to a maximum number of 6 zones and the **PMB112-G** up to 12. The **PMB112-EG** extension module enables 12 programmable shortcut keys for one or more functions to be added. It is possible to connect up to two expansion modules to the PMB112-G.





W-MS24 range • Battery-charging and checking units



W-MS24/150

W-MS24/40

The **W-MS24/4** charging unit, featuring low energy consumption, has an aluminium cabinet covered in ABS. It ensures continuity of services for your system, with an exceptionally good price/performance ratio.

The ease of installation and cabling of this unit, with two charging outputs enabling a larger number of applications and the rated maximum battery-charging capacity not exceeding 55 Ah, are ideal features for using it with the PA8506-V integrated voice evacuation system in medium-sized to small installations, always in accordance with the applicable provisions of law.

The W-MS24/4 battery-charger, which complies in full with EN54-4 (certificate no. **0333-CPD-075192**), is suitable for installing directly on a 19" rack (height: 3 U).

The 24 Vdc **W-MS24/150** and **W-MS24/40** battery chargers have been designed specifically for voice evacuation systems. They are based on microprocessor-driven devices and able to charge lead batteries (back-up batteries connected to the voice evacuation system) and, at the same time, to supply power to auxiliary equipment.

The W-MS24/40 and W-MS24/150 battery chargers meet in full the requirements of EN54-4 (certificates nos. **0333-CPD-075382** and **0333-CPD-075381**), and ensure maximum charging currents of 6 and 12 A respectively. They have standard chassis for installing directly on 19" racks (height: 2 U).



W-MS24/4



W-MS24/WF

The **W-MS24/WF** power supply and battery-charging unit consists of a switching type PSU with protection against short circuits and overloading and a card for managing controlled dynamic recharging of sealed lead batteries (tested regularly) and alarm outputs, a self-testing function and LEDs for signalling 16 different system statuses.

The white-painted metal cabinet can also house the two batteries, providing a compact solution for easy and handy wall-mounting.

The W-MS24/WF, which complies with EN54-4 (certificate no. **0051-CPD-0116**) must be connected to batteries not exceeding a rated output of 27 Ah.

MODEL	W-MS24/40	W-MS24/150	W-MS24/4	W-MS24/WF
Mains power supply	230 Vac \pm 15% - 50/60 Hz			
Maximum load output current	40 A	150 A	4 A	
Main load outputs @24 Vdc	2 x 20 A	6 x 40 A	2 x 4 A	3 x 4 A
Aux load outputs @24 Vdc	3 x 5 A			-
Battery capacity (minimum/maximum)	24 Ah min - 110 Ah max	65 Ah min - 225 Ah max	7 Ah min - 55 Ah max	18 Ah min - 27 Ah max
Nominal output rectifier current	6 A	12 A	3 A	1,5 A
Fault indications	Mains fault, battery fault, output voltage fault			
Low voltage disconnection threshold	21,6 V \pm 3%			
19" rack mounting (modular units)	Direct (2U)		Direct (3U)	Wall mounting
Dimensions (W x H x D)	432 x 88 x 399 mm		482 x 133 x 110 mm	395 x 385 x 185 mm
Weight	3,1 kg	5,4 kg	3 kg	9,6 kg

Master/Slave • 216 zone voice/music control unit

Master unit



Slave unit



The multi-zone system is particularly suitable for large and small installations in which particularly reliable, versatile and practical equipment is required. The simplicity with which the various different units and the control bases can be connected to one another even when far away (CAT 5 connections) makes sound-broadcasting inside complex buildings effective and inexpensive, using both centralised and/or local control units. Both the Master unit (**P8136**) and the Slave unit (**P8236**) enable management of up to six zones each. It is possible to activate/de-activate music for each zone using the front-panel switches provided for this purpose. The Master and Slave units can be used for switching both line signals (one amplifier for each zone) and the power signals (output from the amplifier, 100 V line). In this latter case, it is possible to connect two amplifiers (one for music and the other for speech, two-channel system) or a single voice/music amplifier (single-channel system). To increase the power being managed, the units have provisions for connecting two amplifiers for speech (3 zones each) and two for music. Depending on the size and configuration of the audio system, it is possible to use the Master and/

or Slave units separately or connecting them to one another. The maximum system configuration envisages the use of 6 Master control units connected to 30 Slave units (five for each Master), thus managing up to 216 voice/music broadcasting zones. Up to 16 **PMB106-G** and/or **PMB112-G** microphone consoles can be connected to each unit.

Unlike the Slave unit, on the P8136 there are four inputs for auxiliary sound sources with a selector switch and level control, two line inputs with automatic priority activation (VOX) and four RJ45 inputs for PMB106-G and/or PMB112-G call stations to be configured as Masters and able to control all the zones in the system. The P8136 has provisions for inserting an optional **ACMG8136** card, needed for automatic and/or manual broadcasting of pre-recorded messages. **ACIO8136** cards can also be connected to the same lines as the “local” or “master” microphone stations. These are expansion cards with one balanced line input and 6+6 programmable input/output contacts and they can be used to send pre-recorded messages and/or the incoming audio signal to the various different zones in the system.

FUNCTIONAL FEATURES OF THE P8136 • MASTER UNIT

- CAT 5 RJ45 inputs for:
 - PMB106-G and/or PMB112-G call stations (max. 16)
 - P8136 Master units (max. 1)
 - P8236 Slave units (max. 5)
 - ACIO8136 external I/O cards (max. 6)
- Configuration via software and USB link to a PC
- Two VOX line inputs with automatic activation of priority (telephone/emergency audio inputs)
- Four music inputs (Tape, CD, Tuner, Aux)
- Line input from another Master unit (centralised BGM signal)
- Two separate 100-V inputs for voice and music signals
- Six line-output zones split up into 2 groups of 3 each (100 V / 0 dB depending on how the system is configured)
- Voice and music audio outputs (0 dB)
- Music audio output (0 dB)
- Zone override connection (24 VDC)
- ACMG8136 pre-recorded message generating card (optional)
- Push-buttons for activating music in the six zones
- Push-buttons and encoder for control and configuration
- Power supply: 230 VAC/24 VDC

FUNCTIONAL FEATURES OF THE P8236 • SLAVE UNIT

- CAT 5 RJ45 inputs for:
 - PMB106-G and/or PMB112-G call stations (max. 16)
 - P8136 Master units (max. 1)
 - P8236 Slave units (max. 5)
 - ACIO8136 external I/O cards (max. 6)
- Local music input
- Two separate 100-V inputs for voice and music signals
- Six line-output zones split up into 2 groups of 3 (100 V / 0 dB depending on how the system is configured)
- Voice and music audio output (0 dB)
- Zone override connection (24 VDC)
- Push-buttons for activating music in the six zones
- Power supply: 230 VAC/24 VDC

PAGING MICROPHONE STATION UNITS

With the multi-zone Master/Slave system it is possible to use the PMB106-G and/or PMB112-G pre-amplified desktop microphone stations for All Calls and for calling zones. RJ45 link with CAT5 and SF/UTP shielded cable.





ACCESSORIES

ACIO8136 I/O card unit

- CAT5 master/slave unit connection
- 6 opto-insulated input contacts
- 6 output relay contacts
- 24 Vdc power supply
- 0 dB audio input
- Enable/disable VOX function (telephone/emergency audio input)
- 12 Vdc output



ACMG8136 Pre-recorded message generator

- Optional P8136 master card unit
- SD memory card
- Wav message type
- 127 messages
- microphone input
- Headphone output
- USB connector

MODEL	P8136	P8236
Mains power supply	230 Vac \pm 10% - 50/60 Hz	
Vdc external power supply	24 Vdc	
Mains consumption	30 VA	
Vdc consumption	1,5 A	
Maximum power switchable for single zone	500 W (@ 100 V)	
19" rack mounting (modular units)	Direct (2 U)	Direct (1 U)
Dimensions (W x H x D)	422 x 88 x 167 mm	482 x 44 x 143 mm
Weight	3,9 kg	2 kg



6 zone voice/music control unit



This equipment enables up to six zones to be selected from a microphone base. It is possible to activate/de-activate music for each zone by means of the front-panel switches provided for this purpose. It can be used both with line signals (upstream from the amplifier) and with power signals (output from the 100-V line amplifier). The **P8036** has provisions for connecting two amplifiers (one for music and one for speech) to it or it can be configured for operation with a single amplifier for both voice and music. It has 4 inputs for auxiliary sound sources with a selector switch and level control, an input on a terminal board for connecting several microphone stations (**B711-G** and/or **B711/6-G**) and a VOX priority input for sound sources such as a message or alarm-tone generator. The selected music signal, with a controlled amplitude, will be available on the MUSIC OUT output, while the voice signal from the base or from the VOX input (depending on the priority) will be available on the MIX OUT output. If there is only one amplifier, the music featuring the lowest priority level may also be available on that input. The unit can be installed directly on a 19" rack, occupying the height of one modular unit.

FUNCTIONAL FEATURES

- Selection of voice/music on six zones via relay
- Possibility of activating/de-activating music for each zone by means of front-panel switches
- Four inputs for music sources
- VOX line input with automatic activation of precedence and All Call
- Input for B711 range pre-amplified microphone bases on a screw-down terminal block
- Separate 100-V inputs for music and speech
- Selection of Base/VOX or VOX/Base priority
- Six zone-line outputs on screw-down terminal block with three-wire connection for overriding the local volume attenuators
- MUSIC OUT and MIX OUT outputs
- Service relay for special types of activation (pre-recorded messages, alarm tone, etc.).
- Can be mounted in a 19" rack, height: 1 module
- Power supply: 230 VAC/24 VDC



MODEL	P8036			
Mains power supply (max consumption)	230 Vac \pm 10% - 50/60 Hz (18 W) / 24 Vdc (0,8 A)			
Max power switchable for single zone	500 W (@ 100 V)			
Service relays (12V coil)	$V_{max} = 35 V / I_{max} = 5 A$			
Microphone bases	Pre-amplified B711-G - B711/6-G units (max 5)			
Auxiliary input	CD	TAPE	TUNER	AUX
Type	Unbalanced double RCA			
Sensitivity / Impedance	480 mV / 45 k Ω	100 mV / 33 k Ω		
Noise / Signal ratio	> 80 dB			
Frequency response @-3dB	25 \pm 20.000 Hz			
"BASE INPUT" input	Unbalanced with terminals			
Sensitivity / Impedance	190 mV / 10 k Ω			
Noise / Signal ratio	85 dB			
Frequency response @-3dB	50 \pm 20.000 Hz			
"VOX IN" input	Unbalanced RCA			
Sensitivity / Impedance	300 mV / 46 k Ω			
Noise / Signal ratio	85 dB			
Frequency response @-3dB	30 \pm 20.000 Hz			
Tripping threshold VOX	-30 mV			
Output	MIX. OUT	MUSIC OUT		
Type	Unbalanced RCA			
Output level / Impedance	775 mV / 100 Ω	775 mV / 600 Ω		
19" rack mounting (modular units)	Direct (1 U)			
Dimensions (W x H x D)	482 x 44 x 233 mm			
Weight	3,6 kg			

MICROPHONE BASES FOR ANNOUNCEMENTS AND CONNECTIONS

It is possible to use **B711-G** (All-Call) and/or **B711/6-G** (zone calls) pre-amplified microphone bases, both of which have RJ45 sockets for direct SFTP CAT5 shielded cables (AUDIO IN / AUDIO OUT). B711/6-G stations also have ZONE 1 to 6 sockets for controlling the zone-switching relays. The connectors must be shielded RJ45 connectors. On the P8136, on the other hand, there are two removable bayonet-type terminal blocks for connections: one for the audio and the precedence control ("BASE INPUT") and the other for selecting the zones to be called ("ZONE SELECT").



RJ45	B711-G B711/6-G	P8036 connections	B711/6-G	P8036 connections
PIN	AUDIO IN/OUT	BASE INPUT	ZONE 1 \div 6	ZONE SELECT
1	Audio +	AF	Zone 1	Zone 1
2	Audio -	-	Zone 2	Zone 2
3	GND	GND signal	Zone 3	Zone 3
4	Priority	Priority	Zone 4	Zone 4
5	N. C.	-	Zone 5	Zone 5
6	+ Vdc	+ 12 Vdc	+ Vdc	+ 12 Vdc
7	Serial +	-	Zone 6	Zone 6
8	Serial -	-	GND	-
Shield	GND	GND signal	GND	-



Counter-top intercom system designed to solve problems of communication between areas separated by glazing or walls and in all situations in which, for reasons of safety or hygiene, separation between two speakers is necessary (e.g. ticket booths, bank counters, security guardrooms, reception areas and intensive-care or isolation units).

ITC2000-C is an interphone system for counters for the public. Microprocessor-based management allows high quality flexible performance. The system has more than one operating model. It can be configured as a handsfree “speak-listen” unit and, if connected to an amplifier, it can be incorporated profitably into a sound-broadcasting system. This latter application is extremely interesting, since in addition to carrying on a conversation over the counter, the operator can also make announcements to the public. It can be used with the **LAX50** current amplifier in soundbroadcasting systems for wearers of hearing aids.

The ITC2000-C stands out from other “speak-listen” systems available on the market since it operates in the attenuation mode rather than by switching. This makes the conversation more natural, since the unpleasant breaks in the dialogue that are typical of switched systems

are avoided. The operator station is equipped with a microphone on a flexible stem, long enough to enable conversation in a natural tone of voice and volume, with no howl-round effects. The system must be equipped with either one and two **PASO C401-B** loudspeakers on the public side, for listening. These are made of aluminium, are extremely tough and suitable also for applications requiring protection against vandalism, (e.g. railway and underground, night chemists). In the back panel there are two standard 3,5 mm jack plugs for connecting headphones and/or external microphone.

THE ITC2000-C INTERPHONE SYSTEM CONSISTS OF:

- Microphone base equipped with microphone with anti-hissing protection
- External 230 Vac/18 Vdc, 500 mA power supply
- Junction box (telephone type) with 6-pole socket (female)
- Connecting cable between the interphone base and the junction box (length 3 m), equipped with 6-pin telephone connectors (male)
- Wall-mounted electret microphone, equipped with shielded cable (length 3 m). This microphone was designed for mounting on the glass pane above the counter, thanks to its vibration-proof double-adhesive strip

Note: it works with an external loudspeaker model C401-B, not included in the supply.

MODEL	ITC2000-C
Power-supply voltage/consumption	15 Vdc / 60 mA ÷ 200 mA
Sensitivity of wall-mounted microphone	-47 dB (0 dB = 1V/Pa a 1 kHz)
Sensitivity of station microphone	-48 dB (0 dB = 1V/Pa a 1 kHz)
Frequency response (-3 dB)	270 ÷ 8000 Hz
Internal loudspeaker rated output	1 W
External loudspeaker rated output (8 Ω / 16 Ω)	1 W / 0,6 W
Microphone station dimensions (L x H x W)	200 x 158 x 81 mm
Flush-mounting hole of the microphone station	191 x 155 mm (maximum depth 72 mm)
Microphone station weight	1 kg

MODEL	C401-B
Rated power	3 W
Impedance	16 Ω
Loudspeakers	1
Efficiency (1W/1m)	87 dB
Dispersion angle @2kHz	200°
Frequency response	300 ÷ 12.000 Hz
Dimensions, without bracket (W x H x D)	95 x 105 x 77 mm
Bracket mounting hole	Ø 7 mm
Weight	0,6 kg

SDM200 • RF six audio channel modulator



The SD200 system enables simultaneous distribution of 6 different programmes over a single pair of wires. The ease of installation as compared with conventional systems makes it particularly suitable for sound-broadcasting to the single rooms of accommodation facilities such as hotels, nursing homes, tourist centres, residential centres, cruise ships, ferries and private homes.

SDP220 • Amplified six channel receiver

This unit demodulates the signals distributed by the SDM200 modulator. Even when the receiver is switched off, it can be activated from a remote station, by means of a 12V control. This feature enables forcing of emergency signals to be sent out for single receiving zones. The module can be powered by a 12 VDC source or from the 230 VAC power mains through an SDT100 transformer contained in the SDA200-T loudspeaker module. The channels are selected cyclically by means of keys. The selected channel is shown on a display featuring automatic brightness adjustment in relation to the ambient lighting. The volume control is of the electronic type. It is possible to connect headphones to the socket provided for this purpose. It is available in pale grey (**SDP220**) and anthracite grey (**SDP220-N**).



SDP220



SDP220-N

SDA200 • Loudspeaker

This contains a 3 W / 8 Ω loudspeaker and can be connected to SDP220 receivers that are already powered. It is available in pale grey (SDA200) and anthracite grey (SDA200-N).



SDA200

SDA200-T



SDA200-N

SDA200-TN

SDA200-T • Loudspeaker and power supply for SDP220

In addition to the 3 W / 8 Ω loudspeaker, this module also contains a transformer, SDT100, from the mains 230 Vac voltage for the SDP220 receiver module. Available in light grey colour (**SDA200-T**) or black colour (**SDA200-TN**).

SDB200 • Line amplifier

This module must be used if the length of the line attenuates the signal excessively or, in any case, if the number of SDP220 receivers is greater than 80. Each SDB200 enables a further 80 receivers to be added. It is possible to expand the system to a practically unlimited number of receivers using the appropriate additional SDB200 amplifiers. For the 230 Vac mains power, it is necessary to add the SDT101 transformer. Available in light grey colour (**SDB200**) or black colour (**SDB200-N**).



SDB200



SDB200-N

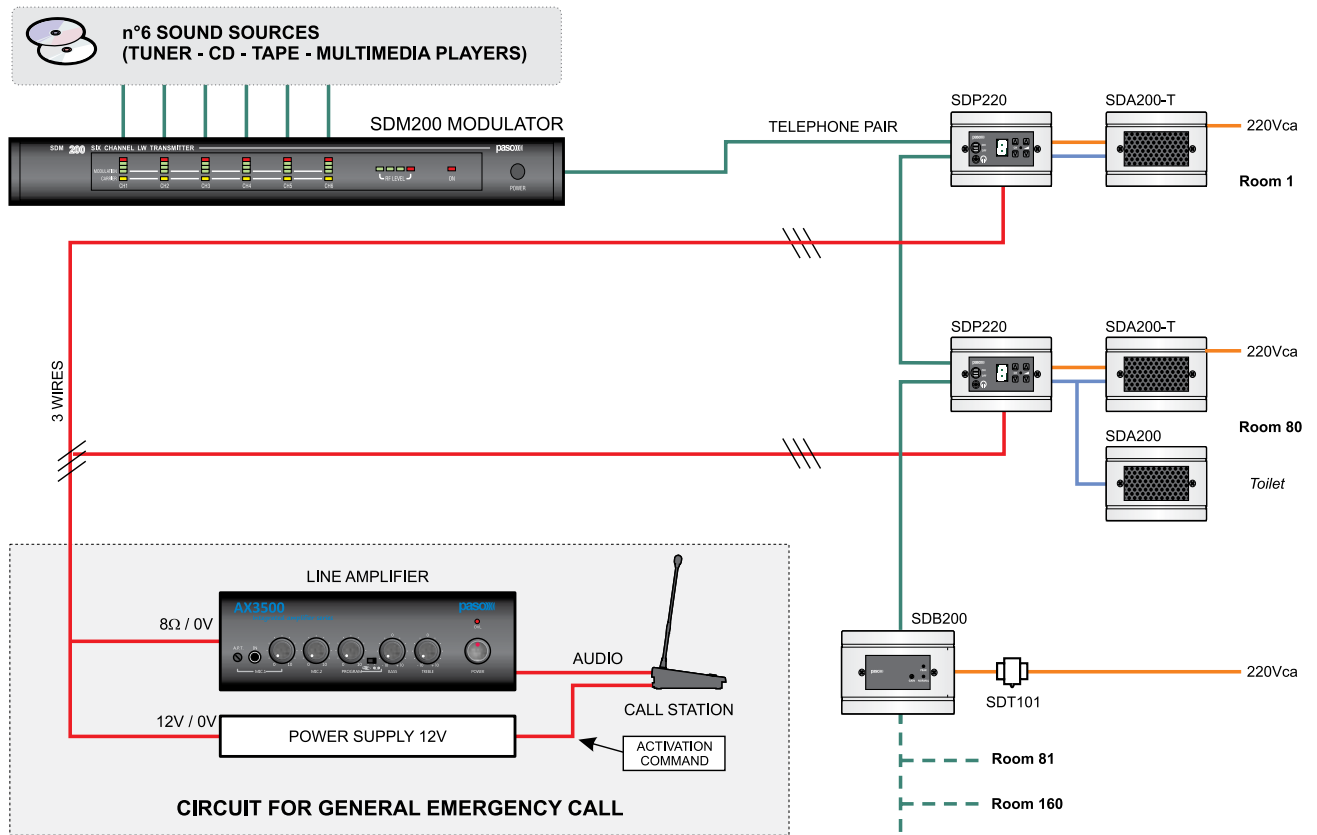

ACCESSORIES

SDT100 Transformer for 230 VAC mains power supply for the SDP220

SDT101 Transformer for 230 VAC mains power supply for the SDB200

27/901 Flush-mounting box for the SDP220, SDA200(-T) and SDB200 modules. Size (WxHxD): 107 x 72 x 53 mm

MODEL	SDP220 SDP220-N	SDA200 SDA200-N	SDA200-T SDA200-TN	SDB200 SDB200-N
Rated power	1 W	3 W		-
Impedance	8 Ω			-
Dimensions (W x H x D)	116 x 77 x 45 mm	116 x 77 x 35 mm	116 x 77 x 55 mm	116 x 77 x 40 mm

MODEL	SDM200
Generator	6 frequencies, PLL type controlled by quartz oscillator
Transmission frequency	CH1=178 kHz; CH2=211 kHz; CH3=244 kHz; CH4=277 kHz; CH5=310 kHz; CH6=343 kHz
Output power	Carrier only: 10 mW / Channel; With modulation: 50 mW Peak / Channel (80% mod.)
Output voltage attenuation	About 0÷26 dB
Output line impedance	25 Ω or 100 Ω
LF input impedance	150 kΩ
Sensitivity for 30% modulation	150÷3.000 mV
Mains power supply	230 Vac ±10% 50/60 Hz
Dimensions (W x H x D)	411 x 44 x 235 mm
19" rack mounting (modular units)	27/2466 optional brackets (1 U)
Weight	3,3 kg

AW25 range

Stereo amplifiers

25 W • Class "D" amplifiers



AW25 25 W stereo amplifier module



AW25-DIN 25 W stereo amplifier unit, standard DIN guides

AW25R-DIN As AW25-DIN with volume control

The models of the **AW25** range are high-efficiency Class D stereo amplifiers. They are small and compact but extraordinarily powerful thanks to the high-quality components with which they are made. They are capable of high performance levels in terms of signal dynamics.

The basic **AW25** card can be installed directly inside electrical junction boxes or in false ceilings, while models **AW25-DIN** and **AW25R-DIN**, supplied with their own boxes, are suitable for installation on standard DIN guides.

Contacts for remote volume control are provided, and if necessary it is possible to set operation simply as a booster unit (maximum volume on switching on). In this way, the output power will be determined by the level of the input power. Model AW25R-DIN has a trimmer-type volume control built into the internal circuit. This enables local adjustment of the volume of the two inputs, LEFT and RIGHT, in addition to any external volume controls.

FUNCTIONAL FEATURES

- Class D stereo amplifier, 25 W maximum
- High-efficiency
- Small and compact sizes (AW25 card version or AW25-DIN and AW25R-DIN models with box suitable for installation on standard DIN guides)
- suitable for sound broadcasting to small areas (hotel rooms, booths of wellbeing centres, meeting rooms)
- 3 different operating modes: STEREO / BRIDGE / PA
- volume control simply by means of remote push-buttons
- 12 ÷ 24 Vdc power supply

The ease of installation, the compact size and the high quality of these amplifiers make them particularly suitable for professional use for separate broadcasting of sound to small areas (e.g. TV signal in hotel rooms, booths of wellbeing centres, signals from video projectors/personal computers in meeting rooms) or for mobile applications such as amplification for market stalls, ships, buses, etc.





An interesting feature of these models is that it is possible to control the volume simply by means of remote push-buttons (similar to common electrical UP/DOWN push-buttons), enabling all sorts of possible uses and making it easy to build them into systems. It is also possible to switch on the amplifiers from a remote station using a remote stand-by switch. A specific service output will enable activation of a signal confirming that they have switched on. These specifications, combined with the possibility of powering the amplifier from a source ranging from 12 to 24 VDC, ensure excellent flexibility and versatility of installation.

OPERATING MODES

The unique feature of these amplifiers is that they can be used in three different modes, depending on requirements:

- **STEREO.** Amplifier with two stereo channels (L + R)
- **BRIDGE** (mono). Amplifier with a single channel featuring a higher output power (bridge connection). If a stereo source is connected to them, the Left and Right inputs are mixed.
- **PA** (mono). Amplifier with two independent channels, the first of which for background music and the second (priority) for calls, by activation from an external contact. The typical sound-broadcasting application for interrupting the background music, by means of a control, when a handsfree call is received.

MODEL	AW25, AW25-DIN, AW25R-DIN			
Operating mode	2 stereo channels		Bridge channels (mono)	
Output power at 12 Vdc (D= 1%)	RL = 8 Ω + 8 Ω	1,5 + 1,5 W	RL = 8 Ω	6 W
	RL = 4 Ω + 4 Ω	2,5 + 2,5 W	RL = 4 Ω	10 W
Output power at 24 Vdc (D= 1%)	RL = 8 Ω + 8 Ω	7+7 W	RL = 8 Ω	25 W
	RL = 4 Ω + 4 Ω	11+11 W		
LINE input sensitivity (12 Vdc / 24 Vdc)	150 / 300 mV rms			
HIGH LEVEL input sensitivity	max 10 V rms			
S/N ratio @12 Vdc	> 80 dB			
S/N ratio @24 Vdc	> 85 dB			
Frequency response	60 ÷ 20.000 Hz (0 ÷ -3 dB)		40 ÷ 20.000 Hz (0 ÷ -3 dB)	
V.OUT output @12/24 Vdc	max 3W			
Mains power supply	11 Vdc (min) ÷ 28 Vdc (max)			
Maximum consumption @12/24 Vdc	1 A / 1,7 A			
Minimum consumption @12V/24 Vdc	60 mA / 70 mA			
Stand-by consumption	12 mA			
Dimensions (W x H x D)	AW25: 95 x 50 x 30 mm - AW25-DIN and AW25R-DIN: 90 x 53 x 58 mm			



PASO is one of the few companies in the business able to boast its own original integrated design industrialisation and manufacturing system for a full range of products, from the most complex and sophisticated equipment to the simplest accessories.

The rack containers of the **P5800-D** range have been designed specifically for housing all PASO electronic equipment and service panels with provisions for modular fixing in 19" racks. All the models of the range are made of thick reinforced steel sheeting and are available in black.

A mounting kit consisting of two sides with ventilation slits, an upper closing panel and a lower one, four feet, a set of screws for mechanical assembly, 4 cables with lugs on the ends for connecting the equipment to earth and a set of caged nuts for securing the service equipment. Black front window panels with double locks are available for opening to the right or to the left (**P5700** range). As an alternative to the normal rear closing panels secured by screws, black blind rear doors with locks and ventilation slits are also available (**P5400-D** range).

The racks of the P5800-D range comply with IEC 297-2 and CEI EN 60065 standards. Also, as called for in the general safety regulations for electrical systems (CEI 64-8, CEI 64-11, CEI 23-48), both the racks and the various different accessories (doors, closing panels, etc.) are equipped with the appropriate terminals for connection to earth.



Rack cabinet
from P5808 to P5840-D

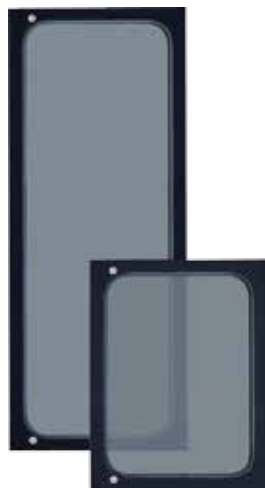

Front window panels
from P5712 to P5740



Blind rear doors
from P5416-D to P5440-D



Blind rear panels
P5404-D
P5408-D
P5410-D



SERVICE PANELS



P8001-B

Panel with 16 Amp mains switch, ON/OFF lamp and mains fuse (1 U).



P8002-M

Monitoring panel with 6-position switch (6 lines), volume control and loudspeakers (1U).



P8004

Panel with main 50 Amp circuit-breaker and ON/OFF lamp. Monitoring section with 6-position switches, loudspeaker and volume control (2 U).



P8003/2-B

Forced ventilation panel complete with two 230 VAC 50/60 Hz fans (3 U).



P8008-D

Mains distribution unit with eight multi-standard sockets.



P8082

Cabled selector switch with 12 switches for activation of the loudspeaker lines and one main switch (1 U).



P8030

Container for special applications with mains switch and ON/OFF lamp.



P8032

Drawer for accessories (3 U).

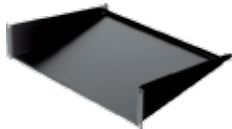

P8035

Top for supporting audio/video sources and various types of equipment (adaptable, 2, 3 and 4 U).

ACCESSORIES



AC50

Pair of side brackets



AC51

Pack of 40 caged nuts (type: M5)



AC52

Pack of 20 screws and 20 washers (type: M5)



AC54-D

Kit consisting of four wheels, load-bearing capacity: 65 kg each



AC5801-D

Foundation base for cabinets with cable output

CLOSING PANELS

Perforated panels

equipped with earth terminals.



P5201-D 1 modular unit

P5202-D 2 modular units

P5203-D 3 modular units

Blind panels

equipped with earth terminals.



P8011-D 1 modular unit

P8012-D 2 modular units

P8013-D 3 modular units

P8014-D 4 modular units

MODEL	P5808	P5812-D	P5816-D	P5820-D	P5824-D	P5830-D	P5840-D
Modular units	8 U	12 U	16 U	20 U	24 U	30 U	40 U
Technical specifications	19" standard rack consisting of two sides with ventilation slits, an upper closing panel and a lower one, a set of screws for mechanical assembly, 4 cables with lugs on the ends for connecting the equipment to earth and a set of caged nuts for securing the service equipment.						
Width	52,5 cm						
Depth	45,6 cm	52,5 cm					
Height	40,8 cm	58,6 cm	76,4 cm	94,2 cm	112 cm	138,6 cm	183,1 cm
Front door	-	P5712	P5716	P5720	P5724	P5730	P5740
Rear door	-	-	P5416-D	P5420-D	P5424-D	P5430-D	P5440-D
Blind rear panels	P5404-D (4 U), P5408-D (8 U) and P5410-D (10 U)						
Colour	Black						
Weight	13,35 kg	17,9 kg	21,2 kg	24,8 kg	28,3 kg	33,2 kg	41,6 kg

Mixer Amplifiers

Booster units

The functional nature and versatility of **PASO** amplifiers are the outcome of many years of experience with these systems.





120 W, 240 W RMS • 3 output zones



This range of built-in amplifiers is characterised by its versatility, user-friendliness, robustness and reliability, designed for a vast range of applications in the field of sound-broadcasting for both commercial and industrial use. The numerous functions offered by the **AX6000** range include three output lines (to zones), CAT5 links to the microphone stations for calling the zones, priority emergency calls to single zones or groups of zones and provisions for a USB/SD card music module. The internal CPU is easily able to manage all the many functions of the equipment and the micro-switches on the rear panel can be used to select the required operating model. All the models have 5 inputs with independent front-panel controls and professional XLR connectors equipped with mechanical locking hold-down devices. The first two are of the electronically balanced microphone type, with a phantom power supply (input 1 with automatic VOX activation).

The third can be used either as a microphone input or as an input for **PMB106-G** microphone stations (RJ45 connector) with the possibility of making calls to zone. The last two can be configured separately, as microphone inputs (with or without phantom power supplies) or as line inputs. There are two auxiliary inputs (CD and TAPE) for connecting sources of music, with normalised input levels and a double RCA socket for using standard stereo cables. There is a special Telephone/Emergency audio input with automatic activation (VOX) that can be used for a priority call. If the system requires acoustic correction, it is possible to connect any equalizer whatsoever or a device for preventing acoustic feedback (Larsen effect) to the PRE OUT and PWR IN sockets after positioning the control switch provided for this purpose. The front panel has a compartment for housing an optional **AC6000** module, enabling external devices such as SD/MMC cards and USB storage units used as sources of music to be played. All the amplifiers of the range ensure a high degree of reliability thanks to electronic devices protecting them from overload currents and over-temperatures of the power devices. Each unit also has a cooling fan, with automatic control of the speed depending on the temperature.

AX6120 120 W RMS mixer amplifier with 3 output zones

AX6240 240 W RMS mixer amplifier with 3 output zones

ACCESSORIES

AC5660 Brackets for rack-mounting (2 U)

AC50 Lateral supporting brackets for rack-mounting

FUNCTIONAL FEATURES

- 2 balanced/unbalanced mic inputs with phantom power supply
- Microphone input or microphone stations of the **PMB** range
- 2 MIC/PH/LINE inputs with specific selector switch
- 2 auxiliary inputs for sound sources (TAPE/CD)
- Telephone/emergency audio input for priority calls with adjustable threshold and sensitivity
- Front-panel adjustment of the level of each microphone and auxiliary input
- Front-panel control of overall volume and of treble and bass tones
- Provisions for inserting a USB/SD CARD module (**AC6000**)
- Constant voltage (50/70/100 V) or 8 Ω impedance loudspeaker line output.
- 3 output lines for zones
- Balanced line output for connection to other amplifiers
- Output/input for connection to audio processors
- LED-type Vu meter for clear and quick reading of power emitted
- Microswitches for setting operating modes
- Includable/excludable speech filters on all microphone inputs
- Contacts for activating input precedence and override
- "Music On Hold" output with output level control (output of the selected auxiliary signal)
- Alerting signal (chime) with level control
- Front-panel keys for selecting music listening zones
- Selectable mains power supply - 230/115 VAC or 24 VDC



AX6000 range Mixer amplifiers

120 W, 240 W RMS • 3 output zones

CONNECTION OF STATIONS

With the amplifiers of the AX6000 range, connecting a PMB106-G microphone station, so as to enable messages to be sent to one or more receiving zones is simple and quickly done. It is essential to use SFTP CAT.5E shielded cables (IN UNITS input), and it is possible to connect up to 16 stations in cascade fashion over a maximum distance of up to 1 km. If necessary, the bases can be powered by means of their rear-panel sockets. The output level is adjustable by means of the appropriate front-panel control (MIC/UNITS).



BACKGROUND MUSIC

This equipment enables activation/de-activation of BACKGROUND MUSIC in the chosen zone by means of the switches provided for this purpose on the front panel. The appropriate LED will light up to confirm that the music has been activated in the zone in question.



CONFIGURATION MICRO-SWITCHES

The main feature of the AX6000 range is the presence of micro-switches on the rear panel enabling the settings of all the operational parameters of the equipment to be checked and/or changed. Specifically, it is possible to manage priorities among the various different audio inputs, to enable a warning signal, to enable VOX (automatic activation) of the MIC1 input and to programme the zones for calls by means of a precedence contact and from the telephone/emergency input.



TELEPHONE/EMERGENCY INPUT

There is a special audio input (TEL/EMERG) on the rear terminal block, balanced with a transformer and with automatic activation of precedence (VOX). Controls for adjusting the level and the activation threshold are provided on the rear panel. This input can be used for connecting the appropriate audio output of a telephone switchboard.



USB/SD card module for the AX6000 range, with remote control

Each amplifier of the AX6000 range has a compartment for housing an optional module enabling an external device such as an SD/MMC card or a USB storage unit to be played. The player has a display for indicating the presence/lack of a SD/MMC/USB medium, the chosen functions and information about the tracks. A remote control unit is also provided with the module.

AC6000 USB/SD Card reader

FUNCTIONAL FEATURES

- Keys for normal control of how the tracks are played out (PLAY/ PAUSE, PREV, NEXT, STOP)
- RANDOM function for playing out the tracks at random
- REPEAT function for playing out one or more pieces of choice
- PROGRAM function for playing out a pre-set sequence of pieces of music





CONNECTIONS

Microphone precedence and warning signal

When the precedence contacts (PR and +12V) on the rear terminal block are closed, all the inputs except for MIC.1 and TEL./EMERG are muted (it is in any case possible to use the micro-switches to program the inputs to be muted and priority of the precedence contact). Closing the contact generates a two-tone warning signal (CHIME).

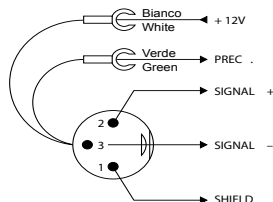

Microphone base B701-MG

Microphone inputs (XLR)

BALANCED connection

- 1 Shield
- 2 Signal (hot side)
- 3 Signal (cold side)

UNBALANCED connection

- 1 Shield and GND
- 2 Signal
- 3 Shield and GND

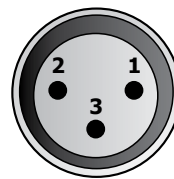

UNITS input (RJ45)

Pin	Description
1	Audio +
2	Audio -
3	GND
4	Not connected
5	Not connected
6	+ Vdc
7	Serial +
8	Serial -
Schermo	GND

All the connectors must be shielded RJ45 type.

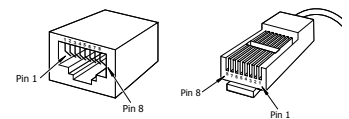

Auxiliary inputs (RCA)

UNBALANCED connection

- 1 Signal
- 2 Shield and GND

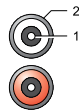

MODEL	AX6120	AX6240
Rated power output	120 W	240 W
Constant voltage outputs / Low impedance outputs	100-70-50 V and 8 Ω	
Tones control	Bass ± 10 dB (100 Hz) ; Treble ± 10 dB (10 kHz)	
Microphone inputs MIC.1 and MIC.2	2 balanced XLR (phantom supply 17,5 V), MIC1 with activation threshold (A.P.T.)	
Sensitivity / Impedance	1,2 mV / 1300 Ω	
S/N Ratio	> 66 dB	
Frequency response	40 ÷ 19.000 Hz	
Microphone input MIC.3/UNITS	Balanced XLR (phantom supply 17,5 V) / 1 RJ45 (PMB106-G base station unit)	
Sensitivity / Impedance	MIC.: 1,2 mV / 1,5 kΩ ; UNITS: 900 mV / 47 kΩ	
S/N Ratio	MIC.: > 66 dB ; UNITS: > 71 dB	
Frequency response	MIC.: 40 ÷ 19.000 Hz – UNITS: 60 ÷ 15.000 Hz	
Maximum number of microphone station units (PMB106-G)	Up to 16 stations in cascade fashion over a maximum distance of up to 1 km; if necessary, the bases can be powered by means of their rear-panel sockets	
Microphone inputs MIC./LINE 4 and 5	2 balanced XLR with Phantom/Mic/Line selection	
Sensitivity / Impedance	MIC: 1,3 mV / 1300 Ω ; LINE: 140 mV / 130 kΩ	
S/N Ratio	MIC: > 66 dB ; LINE: > 75 dB	
Frequency response	MIC: 35 ÷ 17.000 Hz ; LINE: 30 ÷ 20.000 Hz	
Auxiliary inputs	2 RCA (CD + TAPE)	
Sensitivity / Impedance	CD: 600 mV / 35 kΩ ; TAPE: 300 mV / 18 kΩ	
S/N Ratio	> 80 dB	
Frequency response	30 ÷ 20.000 Hz	
Telephone / Emergency (TEL / EMERG) audio input	Balanced with terminals (HOT-COM-GND) with activation threshold adjustment	
Sensitivity / Impedance	120 mV / 5,5 kΩ	
S/N Ratio	> 80 dB	
Frequency response	250 ÷ 20.000 Hz	
Line signal outputs	5	
LINE OUT	XLR balanced 1,3 V / 4 kΩ	
PRE OUT	1 RCA 1 V / 3,7 kΩ	
TAPE OUT	2 RCA 1,2 V / 2 kΩ	
Music On Hold (MOH) - PRE-AMPLIFIED LINE	terminals (HOT-COM) 2,6 V - 300 Ω	
Music On Hold (MOH) - AMPLIFIED LINE	terminals (GND-MON) 1 W - 8 Ω	
Mains power supply	230/115 Vac - 50/60 Hz / 24 Vdc	
Maximum consumption	280 W (325 VA)	530 W (600 VA)
24 Vdc current consumption (max power / with no signal)	6,9 A / 0,3 A	13 A / 0,3 A
19" rack mounting (modular units)	Optional AC5660 brackets with recommended AC50 supports (2U)	
Dimensions (W x H x D)	432 x 88 x 360 mm	
Weight	9,5 kg	11,8 kg

120 W, 240 W, 480 W RMS



This is a new range of power units designed specifically for professional sound-broadcasting systems with service and emergency messages. Thanks to the great reliability of the protection circuits used, combined with an attractive appearance and the very tough structures, the **AW5600** range constitutes the ideal product for quality amplification, with a particularly interesting price/performance ratio.

Each amplifier of the **AW5600** range has an electronically balanced line input/output with a double XLR socket, one female socket and one male socket to facilitate connection of a number of boosters in cascade fashion. To connect a source of sound directly, it is possible to use a second unbalanced input by means of a double RCA socket for using standard stereo cables.

All the boosters of this range have an RJ45 input for connection to **B711-G** pre-amplified microphone bases simply by means of SFTP CAT.5E shielded cables. There is a special balanced input (TEL/EMERG) with a transformer and automatic activation of precedence (VOX) on the rear panel. Controls for adjusting the level and the activation threshold are present on the rear panel. This input can be used for connecting the appropriate audio output of a telephone switchboard.

The AW5600 range has a large number of devices for protection against overloads and short circuits (an output current peak-limiting circuit, a thermal circuit-breaker inside the power transformer, a resettable thermal circuit-breaker in contact with the power-transistor heat sink, mains fuses). In addition, each unit has a cooling fan, with automatic control of the speed depending on the temperatures of the heat sinks to which the power devices are applied.

AW5612	120 W RMS booster unit
AW5624	240 W RMS booster unit ¹
AW5648	480 W RMS booster unit ²

ACCESSORIES

AC5660	Brackets for rack-mounting (2 U)
AC50	Lateral supporting brackets for rack-mounting

FUNCTIONAL FEATURES

- Balanced line input/output (XLR-F and XLR-M sockets, with adjustable sensitivity).
- Unbalanced line input (double RCA socket)
- B711-G microphone station input (RJ45 socket)
- Telephone/emergency audio input for priority calls with adjustable threshold and sensitivity
- Front panel overall volume control and treble and bass controls
- Rear-panel selector switch for enabling/disabling front-panel tone and volume controls
- Constant voltage (50/70/100 V) or 8 Ω impedance loudspeaker line output.
- LED-type Vu meter for clear and immediate monitoring of output power
- Contacts for activating precedence on line input
- Alerting signal (chime) with level control
- Selectable 230/115 VAC and 24 VDC mains power supply

¹ EN54-16:2008 certificate nr. **0068-CPD-081/2011** dated 05 December 2011

² EN54-16:2008 certificate nr. **0068-CPR-082/2013** dated 28 November 2013



MICROPHONE BASES

B711-G microphone stations can be used simply and rapidly with the amplifiers of the AW5600 range. It is essential to use CAT5e SF/UTP shielded cables (IN input UNITS), and it is possible to connect up to 6 microphone stations in cascade fashion. The output level can be adjusted by means of the appropriate rear-panel control (LEV).



FRONT PANEL CONTROL EXCLUSION

If this amplifier is used in emergency systems, it is possible to disable all the front-panel controls (tone and volume controls). In this way it is possible to prevent the levels set at the time of commissioning the system from being altered accidentally.



TELEPHONE/EMERGENCY INPUT

There is a special audio input (TEL/EMERG) on the rear terminal block, balanced with a transformer and with automatic activation of precedence (VOX). Controls for adjusting the level and the activation threshold are provided on the rear panel. This input can be used for connecting the appropriate audio output of a telephone switchboard.



MODEL	AW5612	AW5624	AW5648
Rated power output	120 W	240 W	480 W
Constant voltage outputs / Low impedance outputs	100-70-50 V and 8 Ω		
Tones control	Bass ± 10 dB (100 Hz) ; Treble ± 10 dB (10 kHz)		
Microphone input UNITS	RJ45 (B711-G)		
Sensitivity / Impedance	1250 mV	320 mV	
S/N Ratio	> 78 dB		
Frequency response	30 ÷ 20.000 Hz		
Maximum number of microphone station units (B711-G)	Up to 6 microphone stations in cascade fashion over a maximum distance of up 200 m		
Line input	Balanced XLR, unbalanced RCA		
Sensitivity / Impedance	300 mV / 60 kΩ		
S/N Ratio	>77 dB		
Frequency response	30 ÷ 20.000 Hz		
Telephone / Emergency (TEL / EMERG) audio input	Balanced with terminals (HOT-COM-GND) with activation threshold adjustment		
Sensitivity / Impedance	120 mV / 6 kΩ		
S/N Ratio	>75 dB		
Frequency response	230 ÷ 13.000 Hz		
Line output (LINEA OUT)	Balanced, XLR		
Mains power supply	230/115 Vac - 50/60 Hz / 24 Vdc		
Maximum consumption	280 W (320 VA)	535 W (610 VA)	1160 W (1330 VA)
24 Vdc current consumption (max power / with no signal)	6,6 A / 0,2 A	13,2 A / 0,2 A	33 A / 0,8 A
19" rack mounting (modular units)	Optional AC5660 brackets with recommended AC50 supports (2U)		
Dimensions (W x H x D)	432 x 88 x 272 mm		432 x 88 x 360 mm
Weight	8,2 kg	10,5 kg	16 kg

AX3500 range

Mixer amplifiers

AX3506 • 60 W RMS / AX3512 • 120 W RMS



FUNCTIONAL FEATURES

- 2 mic inputs with phantom power supply (XLR). MIC1 with automatic precedence function (VOX) and adjustable threshold
- Mic input (XLR) with phantom power supply or RJ45 to connect up to 6 B711-G microphone stations (max distance 200 m)
- MIC/PH/LINE input with associated selector switch
- 2 auxiliary inputs for sound sources (TAPE/CD)
- Telephone/emergency audio input for priority calls with adjustable threshold and sensitivity
- Front-panel level control for each microphone and auxiliary input.
- Front panel overall volume control and treble and bass controls
- 50/70/100 V or 8 Ω impedance loudspeaker line output
- Auxiliary line output
- LED-type Vu meter for immediate monitoring of output power
- Microswitches for setting priorities and input functions
- Inclusion/exclusion of speech filter on all microphone inputs
- Contacts for activating input precedence
- Alerting signal (chime) with level control
- Selectable 230/115 VAC and 24 VDC mains power supply

ACCESSORIES

AC3500 Brackets for rack-mounting (AX3506 and AX3512) (2 HE)

Models **AX3506** (output 60 W) and **AX3512** (120 W) have excellent functional features and stand out for their exceptionally good price/performance ratios. The wide range of possible configurations makes each of them a versatile unit able to meet the needs of any small or medium-sized system. Three balanced microphone inputs with phantom power supplies plus an input for **B711-G** microphone bases. There are two auxiliary inputs for sources of sound (Tape, CD) that can be selected by means of the front-panel control. On the rear terminal block there is an audio input with automatic activation of precedence (VOX); the level and activation threshold can be adjusted via the rear panel. This input can be used for connecting the appropriate audio output of a telephone switchboard.

The precedence contact can be used to activate priority of the microphones over the auxiliary sources, sending a warning signal (chime) at the same time. A VU-meter on the front panel indicates clearly the power being output and any overloads. Each amplifier has electronic protection against short circuits on the loudspeaker line. These units can be mounted on a standard 19" rack using the specific **AC3500** brackets.

AX3504 • 40 W RMS



FUNCTIONAL FEATURES

- Front microphone input (jack 1/4"). Input with automatic precedence function (VOX) and threshold adjustment
- Microphone input with phantom power supply (XLR)
- To be used with microphone bases B701-MG and B701-PG
- 2 auxiliary inputs for sound sources (TAPE/CD)
- Telephone/emergency audio input for priority calls with adjustable threshold and sensitivity
- Front-panel level control for each microphone and auxiliary input
- Front-panel treble and bass controls
- Constant voltage (50/70/100 V) or 8 Ω impedance loudspeaker line output
- Auxiliary line output
- Contacts for activating precedence on line input
- Alerting signal (chime) with level control
- Selectable 230/115 VAC and 24 VDC mains power supply

ACCESSORIES

AC3504 Brackets for rack-mounting (AX3504) (2 HE)

The **AX3504** 40 W amplifier is the basic model of the AX3500 range. It is particularly suitable for small systems, and features great flexibility of use thanks to the large variety of inputs and outputs: two microphone inputs (one on the front panel with VOX priority, handy and simple to use), two auxiliary inputs for sound sources (Tape, CD) that can be selected by means of a front-panel control and an audio input with automatic activation of precedence (VOX). A precedence contact activates priority of the microphone over the auxiliary sources, sending a warning signal (chime) at the same time. This unit can be mounted on a standard 19" rack using the specific **AC3504** brackets.



MODEL	AX3506	AX3512
Rated power output	60 W	120 W
Constant voltage outputs / Low impedance outputs	100-70-50 V and 8 Ω	
Tones control	Bass ± 10 dB (100 Hz) ; Treble ± 10 dB (10 kHz)	
Microphone inputs MIC.1 and MIC.2	2 balanced XLR (phantom supply 17,5 V), MIC1 with activation threshold (A.P.T.)	
Sensitivity / Impedance	0,9 mV / 900 Ω	
S/N Ratio	>62 dB	
Frequency response	40 ÷ 20.000 Hz	
Microphone input MIC.3/UNITS	Balanced XLR (phantom supply 17,5 V) / 1 RJ45 (B711-G base station unit)	
Sensitivity / Impedance	MIC.: 0,9 mV / 900 Ω - UNITS: 290 mV / 700 k Ω	
S/N Ratio	MIC.: >62 dB – UNITS: >65 dB	
Frequency response	40 ÷ 20.000 Hz	
Maximum number of microphone station units (B711-G)	Up to 6 microphone stations in cascade fashion over a maximum distance of up 200 m	
Microphone / Line input (MIC / LINE 4)	Balanced XLR with Phantom/Mic/Line selection	
Sensitivity / Impedance (MIC / LINE 4)	MIC: 0,9 mV / 900 Ω - LINE: 90 mV / 50 kΩ	
S/N Ratio MIC / LINE 4	MIC: >62 dB – LINE: >70 dB	
Frequency response MIC / LINE 4	40 ÷ 20.000 Hz	
Auxiliary inputs	2 unbalanced, RCA (CD, TAPE)	
Sensitivity / Impedance	450 mV (CD) – 230 mV (TAPE)	
S/N Ratio	>70 dB	
Frequency response	35 ÷ 20.000 Hz	
Telephone / Emergency (TEL / EMERG) audio input	Balanced with terminals (HOT-COM-GND) with activation threshold adjustment	
Sensitivity / Impedance	150 mV / 6 kΩ	
S/N Ratio	> 72 dB	
Frequency response	250 ÷ 17.000 Hz	
Line signal outputs	Unbalanced, RCA	
LINE OUT	900 mV / 100 Ω	
Mains power supply	230/115 Vac - 50/60 Hz / 24 Vdc	
Maximum consumption	130 W (150 VA)	270 W (320 VA)
24 Vdc current consumption (max power / with no signal)	3,4 A / 0,1 A	6,7 A / 0,2 A
19" rack mounting (modular units)	Optional AC3500 brackets (2U)	
Dimensions (W x H x D)	430 x 88 x 234 mm	
Weight	6,5 kg	9 kg

MODEL	AX3504
Rated power output	40 W
Constant voltage outputs / Low impedance outputs	100-70-50 V and 8 Ω
Tones control	Bass ± 10 dB (100 Hz) ; Treble ± 10 dB (10 kHz)
Microphone inputs MIC.1 and MIC.2	2 balanced (MIC1: Jack 6,5 mm, no phantom - MIC2: XLR with phantom power supply 16,5 V)
Sensitivity / Impedance	1 mV / 1300 Ω
S/N Ratio	MIC.1 >64 dB; MIC.2: >61 dB
Frequency response	35 ÷ 20.000 Hz
Auxiliary inputs	2 unbalanced RCA (CD, TAPE)
Sensitivity / Impedance	520 mV (CD) – 250 mV (TAPE)
S/N Ratio	>73 dB
Frequency response	30 ÷ 20.000 Hz
Telephone / Emergency (TEL / EMERG) audio input	Balanced with terminals (HOT-COM-GND)
Sensitivity / Impedance	150 mV / 6 kΩ
S/N Ratio	> 73 dB
Frequency response	170 ÷ 12000 Hz
Line signal outputs	Unbalanced, RCA
LINE OUT	800 mV / 100 Ω
Mains power supply	230/115 Vac - 50/60 Hz / 24 Vdc
Maximum consumption	100 W (117 VA)
24 Vdc current consumption (max power / with no signal)	2,8 A / 0,1 A
19" rack mounting (modular units)	Optional AC3504 brackets (2U)
Dimensions (W x H x D)	275 x 88 x 230 mm
Weight	4,2 kg



4 kV insulation



The peculiarity of these amplifiers is that they are able to withstand high voltages between the mains power supply/loudspeaker outputs and the frame, even reaching up to 4 kV. This feature increases the safety of the system, preventing possible discharges on the mains or on the loudspeakers connections from passing along the audio chain thus causing serious damage or personal injury.

This built-in amplifier has a standard format that enables it to be mounted also inside telephone type cabinets. The fact that it can be directly wall-mounted using the special backplate enables it to be used in all situations in which there is little room available.

The input of the amplifier is electronically balanced. For special needs, for example in case of particularly long connecting lines or lines prone to interference, it is possible to isolate the input galvanically by means of an optional TM92 card equipped with a line transformer.

Each amplifier is equipped with a diagnostics card able to provide a high number of additional functions (line impedance measurements, amplifier diagnostics, check of integrity of the loudspeaker line, volume control, selection of two inputs, failure-signalling relay control, possibility of including a 'LOW CUT' filter, operation in the 'LOW POWER' energy-saving mode).

In addition to all the operations and/or checks set locally by means of the micro-switches, it will also be possible to alter all the parameters via the TS485 serial interface.

Models **AXF120-HV** and **AXF240-HV** have four inputs with RJ45 sockets on the lower panel: one input for a **B711-G** microphone station (BASE) and three auxiliary inputs (AUX1, AUX2 and AUX3).

These inputs, which are electronically balanced, are switched to one another and have their own order of priority: the BASE input has priority over inputs AUX1/2/3, input AUX1 over AUX2/3 and input AUX2 over AUX3. On each of them, switching of the inputs takes place by means of a positive power supply from outside. There is a voltage on sockets AUX1/2/3 that is cut off in the event of failure of the amplifier or if it is switched off. This enables operation of the amplifier to be monitored from a remote station. There is a 'busy' signal on sockets AUX 2 and AUX 3 when the BASE input or the AUX 1 input are active.

AXF120-HV 120 W RMS mixer amplifier, 4 kV insulation

AXF240-HV 240 W RMS mixer amplifier, 4 kV insulation

AWF120-HV 120 W RMS booster unit, 4 kV insulation

AWF240-HV 240 W RMS booster unit, 4 kV insulation

DIAGNOSTICS

- SPK impedance of loudspeaker line out of spec
- AMP amplifier not working properly
- OVL overloading of loudspeaker line
- HOT thermal overload

MODEL	AWF120-HV	AWF240-HV	AXF120-HV	AXF240-HV		
Rated power output	120 W	240 W	120 W	240 W		
Vdc rated power output	90 W (24 Vdc)	150 W (24 Vdc)	90 W (24 Vdc)	150 W (24 Vdc)		
Constant voltage outputs / Low impedance outputs	100-70-50 V and 8-4 Ω					
Distortion at rated power	< 1 %					
Remote control	Serial RS485					
Inputs	Balanced, XLR		BASE	AUX1	AUX2	AUX3
Sensitivity	770 mV		400 mV	260 mV		
S/N Ratio	> 90 dB		> 85 dB			
Frequency response	40 ÷ 30.000 Hz		60 ÷ 19.000 Hz			
Secondary input	Balanced with terminals					
Sensitivity	720 mV					
Frequency response	50 ÷ 18.000 Hz					
Distortion	< 0,5%					
Mains power supply	230 Vac - 50/60 Hz / 24 Vdc			230 Vac - 50/60 Hz		
Maximum consumption	250 W / 300 VA	500 W / 600 VA	250 W / 300 VA	500 W / 600 VA		
24 Vdc current consumption (max power / with no signal)	6,5 A	11 A	6,5 A	11 A		
Dimensions (W x H x D)	150 x 368 x 150 mm			150 x 365 x 150 mm		
Weight	7,4 kg	10,7 kg	7,4 kg	10,7 kg		



Systems for hearing-aid wearers



The amplifiers of the **LAX** range are designed specifically for inductive sound transmission and are used in particular in dedicated audio systems for hearing-aid wearers. Most modern hearing aids have a two-position switch, the positions being marked "M" and "T". Position "M" is for "normal" listening through the microphone. Position "T" (Telecoil) is for inductive sound reception, through a special coil built into the hearing aid.

The output from the current amplifier feeds a loop made of suitably insulated normal copper wire positioned on the perimeter within which to broadcast sound. The current running through the loop generates a variable magnetic field in the room that is "induced" in the coil of the hearing aid. As a rule, this magnetic field is sufficiently strong to enable the person to move about freely, still enjoying a comfortable level of reception.

The main advantage of this system is that the sound reaches the user in an undistorted manner free from any ambient noise, echo or reverberation, and is therefore perfectly intelligible. The use of induction systems for hearing-aid wearers is becoming increasingly widespread in public places such as theatres, churches, banks, schools and offices etc., and there are also effective and increasingly numerous household applications, with connections to the television set, the radios, the telephone and/or the door-phone.

LAX200 Current amplifier up to 200 mq

LAX450 Current amplifier up to 450 mq

LAX800 Current amplifier up to 800 mq



LAX50 Current amplifier up to 50 mq

ACCESSORIES

LACF01 Feeder cable, 50 m

LACL10 Loop feeder cable, 100 m

LAC50 Induction coil for counters or tables (LAX50)

LALT01 Scotch tape for LACF01, 50 m

LAL01 Loop present stickers (10 pcs.)

LAM50 Tie clip microphone (LAX50)

LASC100 SCART adaptor for TV (LAX200/450/800)

LASC50 SCART adaptor for TV (LAX50)

LATR100 Interface for 100 V line (LAX200/450/800)

LATR50 Interface for 100 V line (LAX50)

Measuring instruments



LASFM01 Magnetic-field measuring instrument

This instrument enables accurate measurement of the magnetic field inside the area covered by the current loop and therefore control of the installation and regular maintenance.



LARX01 Sample receiver

This enables reception and control of the programme being transmitted by means of the magnetic induction system. It is supplied complete with headphones.

MODEL	LAX200	LAX450	LAX800	LAX50
Audio inputs	3, XLR (2 balanced microphones, 1 MIC/LINE selectable) - Phantom 15 V selectable			2 micro (jack mono 3,5 mm) with phantom 4,5 V
Sensitivity	-50 dB (MIC), -10 dB (LINE)			-50 dB
Impedance of loop	from 0,1 Ω to 1 Ω			
RMS current	2 A (@ 1 KHz)	3 A (@ 1 KHz)	4 A (@ 1 KHz)	1,5 A (@ 1 KHz)
Mains power supply	230 Vac - 50/60 Hz			
Consumption	100 VA max	180 VA max	300 VA max	20 VA max
Dimensions (W x H x D)	430 x 44 x 220 mm			91 x 170 x 33 mm
19" rack mounting	Optional 27/4555 baskets (1U)			-
Weight	3,7 kg	4 kg	4,3 kg	0,6 kg

CMDS Compact Music Distribution Systems

Sound sources

Mixer

PASO compact systems, sound sources and mixers provide many possible solutions for broadcasting music and messages able to meet any needs in the most appropriate and effective manner.





Amplified Sinto-CD/mp3 and USB/SD Card player • 6 output zones



PA6120 120 W RMS compact system with 6 output zones

PA6240 240 W RMS compact system with 6 output zones

The **PA6240** and **PA6120** compact systems combine in a single container a multi-function sound source (CD-MP3 player, USB, SD/MMC card and AM/FM tuner) and an amplifier-mixer, 120 W and 240 W RMS respectively, with six output zones and separate volume control. They have an internal CPU able to manage easily the many functions of the equipment. Specific micro-switches on the rear enable the desired operating mode to be selected.

Designed starting out from the amplifier-mixers of the AX6000 range, all PA6000 models have five inputs with independent front-panel controls and with professional XLR connectors with mechanical holding devices. The first two are of the electronically balanced microphone type, with a phantom power supply (input 1 with automatic VOX activation). The third can be used either as a microphone input or as an input for PMB106-G microphone stations (RJ45 connector) with the possibility of making zone calls. The last two can be configured separately, as microphone inputs (with or without phantom power supplies) or as line inputs.

There are two auxiliary inputs (CD and TAPE) for connecting to external sources of music, with normalised input levels and a double RXA socket for using standard stereo cables.

There is a special Telephone/Emergency audio input with automatic activation (VOX) that can be used for a priority call. If the system requires acoustic correction, it is possible to connect any equalizer whatsoever or a device for protection against acoustic feedback (Larsen effect) to the PRE OUT and PWR IN sockets after positioning the control switch provided for this purpose. All the models of the range ensure a high degree of reliability thanks to electronic devices protecting them from overload currents and over-temperatures of the power devices. Each unit also has a cooling fan, with automatic control of the speed depending on the temperature.

FUNCTIONAL FEATURES

- 2 balanced/unbalanced microphone inputs with phantom power supplies
- Microphone input or microphone bases of the PMB range
- 2 MIC/PH/LINE inputs with associated selector switch
- 2 auxiliary inputs for sound sources (TAPE/CD)
- Telephone/emergency audio input for priority calls with adjustable threshold and sensitivity
- Front-panel level controls for each microphone and auxiliary input
- Front panel overall volume control and treble and bass controls
- Multi-purpose sound source module with CD-MP3/ USB/SD CARD player and AM/FM tuner
- Constant voltage (50/70/100 V) or 8Ω impedance loudspeaker output lines
- 6 output lines (zones) with front-panel level control for the music signal for each single zone
- Balanced line output for connection to other amplifiers
- Output/input for connection to audio processors
- Connection to an external amplifier for simultaneous music and speech in different zones
- LED-type Vu meter for clear and immediate monitoring of output power
- Microswitches for setting the operating modes
- Inclusion/exclusion of speech filter on all microphone inputs
- Contacts for activating input precedence and override
- "Music On Hold" output with output level control (output of selected auxiliary signal)
- Alerting signal (chime) with level control
- Selectable 230/115 VAC and 24 VDC mains power supply

ACCESSORIES

AC50/3 Brackets for rack-mounting (3 HE)



PA6000 range

CMDS (Compact Music Distribution System)

Amplified Sinto-CD/mp3 and USB/SD Card player • 6 output zones

CONNECTION OF STATIONS

With the compact systems of the PA6000 range, connecting a PMB106-G microphone station, so as to enable messages to be sent to one or more receiving zones is simple and quickly done. It is essential to use SFTP CAT.5E shielded cables (IN UNITS input), and it is possible to connect up to 16 stations in cascade fashion over a maximum distance of up to 1 km. If necessary, the bases can be powered by means of their rear-panel sockets. The output level is adjustable by means of the appropriate front-panel control (MIC/UNITS).



MUSIC VOLUME CONTROL

These units enable separate control of the volume of the background music broadcast to the single zones, thanks to the specific front-panel 'ZONE MUSIC LEVEL' controls.



CONFIGURATION MICRO-SWITCHES

The main feature of the PA6000 range is the presence of micro-switches on the rear panel enabling the settings of all the operational parameters of the equipment to be checked and/or changed. Specifically, it is possible to manage priorities among the various different audio inputs, to enable a warning signal, to enable VOX (automatic activation) of the MIC1 input and to programme the zones for calls by means of a precedence contact and from the telephone/emergency input.



TELEPHONE/EMERGENCY INPUT

There is a special audio input (TEL/EMERG) on the rear terminal block, balanced with a transformer and with automatic activation of precedence (VOX). Controls for adjusting the level and the activation threshold are provided on the rear panel. This input can be used for connecting the appropriate audio output of a telephone switchboard.



Multi-function module

Each unit of the PA6000 range has a multi-function module with a tuner/ CD/MP3 player that also enables external devices such as SD/ MMC cards to be played and an USB storage unit.

The module has a display for indicating the presence or lack of CD/ SD/MMC/USB media, the chosen functions, information about the tracks and the type of tuning selected. All the keys needed for control of the module are accessible on the front panel: selection of the device to be used, controls for playing out the tracks in the normal module, programming functions for listening to the pieces of music, repeating them or playing them out in random order. The AM/FM tuner can be used for automatic or hand tuning and for storage of 10 programmes in both bands.





EXTERNAL CALL AMPLIFIER

With a single internal amplifier, the compact system functions in the single-channel mode: a zone call will interrupt the background music also in those areas not receiving the call. With the PA6000 it is possible to connect an external dedicated voice amplifier. In this way it will be possible to receive both announcements and background music in different zones at the same time.

MUSIC ON HOLD OUTPUT

The presence of the Music On Hold output (MOH OUTPUT) provides an interesting function. The signal from the selected sound is always available, without being subject to any type of precedence. On the output terminal block provided for this purpose, there are a balanced line signal with a transformer (COM-HOT terminals) for connection to other

equipment or to a telephone exchange, and a power signal (MON-GND terminals) for driving directly an 8 Ohm/1 W monitoring loudspeaker. The output level can be controlled directly from the rear panel.

CALLS TO ZONES

The unique feature of this equipment is that the group of zones to be activated for each available source of calls can be configured: the PMB106-G microphone stations can be used, directly via the keypad, to send a call to one or more receiving zones; the announcements to be made with automatic activation of the MIC.1 input, those to be made with the emergency input (TEL./EMERG) and those to be made by closing the precedence contact may affect one or more receiving zones, depending on the settings made by means of the micro-switches on the rear panel.

MODEL	PA6120	PA6240
Rated power output	120 W	240 W
Constant voltage outputs / Low impedance outputs	100-70-50 V and 8 Ω	
Tones control	Bass ± 10 dB (100 Hz) ; Treble ± 10 dB (10 kHz)	
Microphone inputs MIC.1 and MIC.2	2 balanced XLR (phantom supply 17,5 V), MIC1 with activation threshold (A.P.T.)	
Sensitivity / Impedance	1,2 mV / 1300 Ω	
S/N Ratio	> 66 dB	
Frequency response	40 ÷ 19.000 Hz	
Microphone input MIC.3/UNITS	Balanced XLR (phantom supply 17,5 V) / 1 RJ45 (PMB106-G base station unit)	
Sensitivity / Impedance	MIC: 1,2 mV / 1,3 kΩ ; UNITS: 850mV / 800 kΩ	
S/N Ratio	MIC: >66 dB ; UNITS: >76 dB	
Frequency response	MIC: 30 ÷ 20.000 Hz ; UNITS: 30 ÷ 20.000Hz	
Maximum number of microphone station units (PMB106-G)	Up to 16 stations in cascade fashion over a maximum distance of up to 1 km; if necessary, the bases can be powered by means of their rear-panel sockets	
Microphone inputs MIC./LINE 4 and 5	2 balanced XLR with Phantom/Mic/Line selection	
Sensitivity / Impedance	MIC: 1,2 mV / 1,3 kΩ ; LINE: 110 mV / 130 kΩ	
S/N Ratio	MIC: >66 dB ; LINE: >77 dB	
Frequency response	MIC: 30 ÷ 20.000 Hz ; LINE: 30 ÷ 20.000 Hz	
Auxiliary inputs	2 RCA (CD + TAPE)	
Sensitivity / Impedance	CD: 450 mV / 35 kΩ ; TAPE: 220 mV / 18 kΩ	
S/N Ratio	> 80 dB	
Frequency response	30 ÷ 20.000 Hz	
Telephone / Emergency (TEL / EMERG) audio input	Balanced with terminals (HOT-COM-GND) with activation threshold adjustment	
Sensitivity / Impedance	105 mV / 6 kΩ	
S/N Ratio	> 74 dB	
Frequency response	200 ÷ 20.000 Hz	
Line signal outputs	5	
LINE OUT	XLR balanced, 1 V / 3,9 kΩ	
PRE OUT	RCA, 0,8 V / 3,8 kΩ	
TAPE OUT	2 RCA, 0,9 V / 2 kΩ	
Music On Hold (MOH) - PRE-AMPLIFIED LINE	terminals (HOT-COM), 2 V / 300 Ω	
Music On Hold (MOH) - AMPLIFIED LINE	terminals (GND-MON), 1,9 W / 8 Ω	
Mains power supply	230/115 Vac - 50/60 Hz / 24 Vdc	
Maximum consumption	280 W (325 VA)	510 W (590 VA)
24 Vdc current consumption (max power / with no signal)	6,8 A / 0,2 A	13,1 A / 0,3 A
19" rack mounting (modular units)	Optional AC50/3 brackets (3U)	
Dimensions (W x H x D)	432 x 133 x 360 mm	
Weight	14 kg	16,5 kg

Amplified Sinto/USB/SD Card player • 60 W / 120 W / 240 W



When it comes to CMDS systems, the **PA1000** range has excellent functional characteristics and stands out for its exceptionally good price/performance ratio. A multi-function module with a digital FM tuner, an MP3 player for a USB/SD-MMC card, an amplifier-mixer and the wide range of possible configurations make each of these units a versatile sound-broadcasting system able to cover the needs of any small or medium-sized installation. The XLR sockets on the rear panel can be configured separately as microphone inputs (with or without phantom power supplies) or as line inputs: the mode is selected by means of the specific three-position switches.

Each of these inputs has its own level control for metering the amplitude of the various different signals suitably. Furthermore, the INPUT1 microphone input has an automatic precedence function (VOX): when the microphone connected to this input is used to speak, all the music and microphone inputs will automatically be muted. For connection to external music sources there is an auxiliary input with a double RCA socket for using standard stereo cables. It is possible to connect all dynamic microphones and **B701-MG** microphone bases to PA1000 compact systems. A precedence terminal block on the rear panel enables signals from the MP3 player, from the tuner and from the auxiliary input to be muted.

If, due to a particularly difficult environment, the system requires acoustic correction, it is possible to connect any equalizer whatsoever or a device for preventing acoustic feedback (Larsen effect) to the PRE OUT and PWR IN sockets. All the models ensure a high degree of reliability thanks to electronic devices protecting them from overload currents and over-temperatures of the power devices. Each unit also has a cooling fan, with automatic control of the speed depending on the temperature.

PA1060 60 W RMS compact system

PA1120 120 W RMS compact system

PA1240 240 W RMS compact system

FUNCTIONAL FEATURES

- MP3 player module (via USB, SD or MMC card)
- Digital FM tuner
- 3 MIC./LINE inputs with mode selection
- 1 VOX input (INPUT 1)
- 1 auxiliary input for sources of sound (TAPE/CD)
- Front-panel level control for each microphone and auxiliary input
- Front-panel master volume control and treble and bass control
- XLR sockets for connecting dynamic microphones and/or B701-MG stations
- Constant-voltage (25/70/100 V) or 4Ω impedance loudspeaker line output terminal block
- Terminal block for activating precedence of microphone inputs
- Output/input for connection to audio processors
- Unbalanced line output for connection to other amplifiers
- LED-type Vu meter for clear and immediate check of output power
- Terminal block for DC power (24 VDC)
- Selectable mains power (230/115 VAC)
- Mountable in standard 19" rack using optional brackets

ACCESSORIES

AC5660 19" rack mounting brackets (2U)





CONNECTIONS

Microphone precedence

When the precedence contacts (P and +) on the rear terminal block are closed, all the music sources and auxiliary input are muted.

Microphone base B701-MG

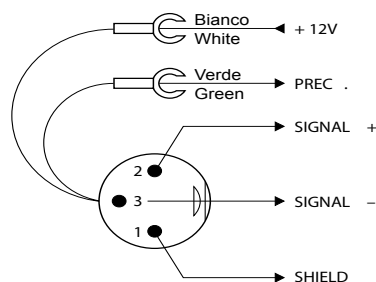

Microphone inputs (XLR)

BALANCED connection

- 1 Shield
- 2 Signal (hot side)
- 3 Signal (cold side)

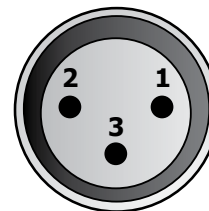

UNBALANCED connection

- 1 Shield and GND
- 2 Signal
- 3 Shield and GND

Auxiliary input (RCA)

UNBALANCED connection

- 1 Signal
- 2 Shield and GND

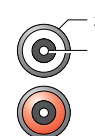

MODEL	PA1060		PA1120		PA1240	
RMS output power (THD <1%)	60 W		120 W		240 W	
Constant voltage outputs			100, 70, 25 V			
Low impedance outputs			4 Ω			
Tones control						
Bass tones @100 Hz			± 12 dB			
Treble tones @10 kHz			± 11 dB			
Microphone/line inputs	MIC.	LINE	MIC.	LINE	MIC.	LINE
Input sensitivity / impedance	3 mV / 1,5 kΩ	250 mV / 100 kΩ	3 mV / 1,5 kΩ	250 mV / 100 kΩ	3 mV / 1,5 kΩ	250 mV / 100 kΩ
S/N Ratio	68 dB	72 dB	70 dB	76 dB	70 dB	76 dB
S/N Ratio ('A' weighted)	73 dBA	80 dBA	73 dBA	82 dBA	73 dBA	82 dBA
INPUT 1 VOX activation threshold	0,9 mV	-	0,9 mV	-	0,9 mV	-
Frequency response			35 ÷ 16.000 Hz			
Phantom supply	18 V / 2,2 kΩ	-	8 V / 2,2 kΩ	-	18 V / 2,2 kΩ	-
Auxiliary input						
Sensitivity / Impedance			400 mV / 22 kΩ			
S/N Ratio	78 dB		80 dB		80 dB	
S/N Ratio ('A' weighted)	85 dBA		82 dBA		85 dBA	
Frequency response			30 ÷ 18.000 Hz			
VOX and precedence attenuation			-60 dB			
PWR IN input						
Sensitivity / Impedance			1 V / 22 kΩ			
S/N Ratio	85 dB		93 dB		93 dB	
S/N Ratio ('A' weighted)	100 dBA		100 dBA		100 dBA	
Frequency response			30 ÷ 18.000 Hz			
LINE OUT output						
Output level / Impedance			1 V / 200 Ω			
PRE OUT output						
Output level			1 V			
Mains power consumption						
			230/115 Vac - 50/60 Hz / 24 Vdc			
Maximum consumption	P= 150 W		P= 300 W		P= 600 W	
Vdc maximum consumption	4 A		10 A		20 A	
Dimensions (W x H x D)			430 x 88 x 270 mm			
Weight	6,3 kg		8,3 kg		10,5 kg	



P8083 • CD-MP3/USB/SD Card player and FM/AM stereo tuner



A single container that can be mounted in a standard 19" rack and is one modular unit high, comprises a CD-MP3/USB/SD Card player and an FM/AM stereo tuner. Volume control and independent audio outputs on a double RCA socket for both sources of sound. There is an additional combined audio output from which it is possible to pick up both signals of the modules with priority of the CD player over the tuner. The CD player module has a back-lit display, a shockproof system,

and normal, repeat, random or programmed play functions. The CD player is supplied with a remote control enabling full remote management. Stereo FM/AM tuner module with backlit display, automatic and/or manual tuning, pre-selection of up to 20 stations (10 FM plus 10 AM), and SLEEP function. FM and AM aerial included.

Power supply requirements: 230/115 VAC - 50/60 Hz / 24 VDC.

Size (LxHxD): 482 x 44 x 285 mm

P8083-R • Digital USB/SD Card player/recorder



The **P8083-R** is a digital recorder and player for audio files in MP3 format on external storage devices such as SD cards or USBs (playing of MP3/WMA audio files and recording in MP3 format). Front-panel master volume control. Rear-panel line input and output on a double RCA socket. Management of external storage devices from 128 MB to 16 GB (SD Card/USB). Possibility of selecting the recording quality (128 Kbps or 192 Kbps). Recordable audio tracks up to a maximum of 99. It is possible to programme customised sequences for playing

out the music and to select and repeat a single section of a piece of music. Files can be deleted and it is possible to copy data from a USB to an SD card or vice versa. Large backlit display for showing the various different functions. A remote control enabling full remote management is supplied with the equipment. The P8083-R has provisions for mounting in a standard 19" rack and has the height of a single unit. Power supply requirements: 230/115 VAC - 50/60 Hz / 24 VDC.

Size (LxHxD): 482 x 44 x 285 mm

Module available on request

Other models created by combining various different modules of the P8083 range are available on request. They all feature a standard container suitable for mounting in a standard 19" rack and of the height of one modular unit. Double RCA sockets are provided for connecting the line outputs on the rear panels, using standard stereo cables.

Power supply requirements: 230/115 VAC - 50/60 Hz / 24 VDC.

Size (LxHxD): 482 x 44 x 285 mm

P8083-ALL

CDM-P3/USB/SD CARD player and FM/AM tuner. Master volume control. Backlit display. CD player with shock-absorbing system.



normal, repeat, random or programmed play functions. Tuner with automatic scanning and pre-selection of up to 20 stations (10 FM and 10 AM stations). Remote control and aerials included in the supply.

P8083-2ALL

Model with two CD-MP3/USB/SD CARD player module and FM/AM stereo tuner module.

P8083-T

FM/AM stereo tuner. Master volume control, backlit display, automatic and



manual tuning, pre-selection of up to 20 stations (10 FM and 10 AM stations) and SLEEP function. FM and AM aerial included in the supply.

P8083-2T

Two FM/AM stereo tuners.

P8083-P

CDM-P3/USB/SDCARD player with PITCH speed control. Master volume



control and control of speed at which the audio tracks are played out (PITCH). Backlit display, shock-absorbing system and normal, repeat, random or programmed play functions. Remote control included in the supply.



MX5539 • Audio mixer 9 input and 2 output



The **MX5539** mixer is a pre-amplifier and mixer with advanced technical features. Its versatility and user-friendliness make it suitable for a vast range of professional applications. The number of inputs at disposal and which can be further expanded, the PHANTOM power supply for the electret microphones and microphone priority are just a few of the most important features of this product.

The MX5539 mixer can be used either as a conventional mixer for microphones or to manage small conferences, thanks to the microphone precedence circuit. It is possible to connect two or more mixers in cascade fashion in order to increase the total number of inputs at disposal. The LCFs (Low Cut Filters) introduce basic equalising for improving the intelligibility of speech.

FUNCTIONAL FEATURES

- MIC1 input with voice activation (VOX) with priority over all the other inputs
- 8 inputs with selectable sensitivity (Mic/Mic-LCF/Line)
- Phantom power supply on all microphone inputs
- Selection of the output channel for each input (L, R or L+R)
- Separate level control for each input
- Two balanced output channels (L and R)
- Tone control and master level control for each output
- Output for recorder
- Contact-based priority of MIC1 input over inputs 2 to 9
- Voice activation of MIC2 and MIC3 over MIC2 to MIC9 (enabled via the front panel)
- Four-tone warning signal activated by means of a contact or push-button, level control and output channel control

DLC9000 • Automatic controller of audio level



FUNCTIONAL FEATURES

- Level of background noise shown in real time
- Storage of background noise level (minimum and maximum)
- Level of attenuation definable on the basis of the required S/N ratio
- Incremental adjustment of the ratio
- "Precedence" contact or "VOX" function for emergency calls
- Monitoring loudspeaker

The DLC9000 is a device for automatic control of the audio level for broadcasting messages in places featuring variable background noise levels such as, by way of example, a railway station or a chain store where the level of the background noise is higher when the area is crowded than when there is no movement. The DLC9000 uses a microphone, not included in the supply (for example, an M936 dynamic microphone or an MC102 flat electret microphone) to detect the ambient noise. The output of the control is connected between the pre-amplifier and the power amplifier of the zone considered.

The noise measuring device is extremely simple to configure. The various different stages of programming can be selected easily using only three push-buttons (Up/Down and Select) in the menu shown on the 16-digit backlit display.

DAG9300 • Alarm-tone generator and voice recorder



The DAG9300 is an alarm-signal generator that can be used to record and play out two voice messages. 12 different alarms (to be chosen from among the 20 different synthesised tones available). The tones and pre-recorded messages can be activated either by means of the front-panel controls or by means of contacts on the rear panel. One very interesting feature is that a microphone station of the **B711** range can be used to record a voice message and play it out with a certain

delay after completion of the recording ("DELAY PLAY" mode). In this way it will be possible to make voice announcements to be broadcast with a certain delay, so as to avoid triggering the Larsen effect, created when the microphone is too close to the loudspeakers. With the "REC PLAY" mode, on the other hand, it will be possible to use the base for sending out a pre-recorded message.

Microphones

Microphone bases

Wireless microphones

PASO offers a full range of professional microphones, microphone bases and wireless microphones that combine exclusive design and specific technical characteristics able to meet any need.



Microphones



Dynamic microphones



M976

Very sensitive one-directional dynamic microphone with a hyper-cardioid pattern, suitable for use for both speech and music. Its special elastic suspension and its high degree of directivity make it advisable also in difficult situations with acoustic feedback problems (Larsen effect). It has an ON/OFF switch and a 5-metre long XLR/XLR cable, a coupling for mounting on a stand and a handy carrier case are included in the supply.

M936

Unidirectional dynamic microphone with a cardioid pattern for general use. It features high sensitivity, particularly good intelligibility of speech and good reproduction of music. The supply includes an ON/OFF switch, a 5-metre XLR/XLR cable, a coupling for mounting on a stand and a carrier case.



M1-NC

Unidirectional dynamic microphone with PTT push button, 1.5 m spiralled cable and XLR plug.



Electret microphones

MC102 • MC102-N

Ultra-flat surface microphones with a hemi-cardioid polar pattern. They are used on flat horizontal surfaces (tables, floors). Their peculiar directivity characteristics (60° from the front in respect of the surface on which they rest) makes them particularly suitable for conferences, religious ceremonies and/or theatrical events.

Phantom power supply and 5-metre long cable with carrier case.



MC250

Pen microphone with a hyper-cardioid polar pattern. It ensures high levels of useful signal with a limited receiving angle, thus keeping the impact of surrounding noises to a minimum. It has a very extensive frequency response. It is suitable also for critical receiving situations at some distance from the source with minimum sensitivity to the Larsen effect. Phantom power supply. It has a voice-filter switch, a 4.5-metre long cable, a coupling for mounting on a stem, a wind screen and a carrier case.



MC260 • MC265

Family of electret microphones featuring an elegant appearance and able to meet the increasingly demanding specifications of architectural design and interior decoration of halls, conference rooms and places of worship. The cardioid type response of the microphone housing and the very sensitive electret capsule make these microphones perfect for enhancing the user's oratory qualities.

B260

Table-top base for MC260 and MC265 microphones. ON/OFF switch, XLR/F connector with mechanical locking device for fitting a microphone and rear XLR/M output connector. Black die-cast zinc structure. Size (LxHxD): 120 x 40 x 125 mm. Weight: 1.2 kg.



MC260 Electret microphone with a double-jointed stem 55 cm long

MC265 Electret microphone stem flexible at the base, 42 cm long

MODEL	M1-NC	M936	M976	MC102 MC102-N	MC250	MC265	MC260
Characteristics	Dynamic unidirectional, cardioid		Dynamic unidirectional, hypercardioid	Electret unidirectional, hemicardioid	Electret, hypercardioid		Electret, cardioid
Power supply	-			Phantom 11 ÷ 52 Vdc		Phantom 9 ÷ 52 Vdc	
Impedance	600 Ω	600 Ω	600 Ω	100 Ω	150 Ω	200 Ω	
Sensitivity	-78 dB/μbar	-72 dB/μbar	-71 dB/μbar	-65 dB/μbar	-54 dB/μbar	-58 dB/μbar	
Frequency response	100 ÷ 10.000 Hz	50 ÷ 15.000 Hz	50 ÷ 16.000 Hz	50 ÷ 16.000 Hz	20 ÷ 20.000 Hz	50 ÷ 18.000 Hz	
Body	ABS		Die-cast Zn-Al		Die-cast Al	Brass	
Finish	Black	Anthracite grey mat		White (MC102) Black (MC102-N)	Black mat		Black
Supplied accessories	1,5 m spiralled cable (XLR)	5 m detachable cable (XLR), jointed microphone support and shock-proof carrying case		5 m detachable cable (Micro-XLR/ XLR) and shock-proof carrying case	4,5 m detachable cable (XLR) jointed microphone support and shock-proof carrying case		-
Dimensions (W x H x D)	100 x 60 x 50 mm	Ø 53 x 170 mm	Ø 53 x 170 mm	90 x 17 x 115 mm	Ø 23 x 163 mm		Ø 19 x 424 mm (Ø 7 stem) Ø 19 x 550 mm (Ø 7 stem)
Weight	165 g	236 g	290 g	264 g	148 g	124 g	140 g

Microphones

B700 range • Microphone bases

Pre-amplified microphone bases

Each unit has an electret microphone and a stem with a flexible part on the base. They can run on a 12 and/or 24 VDC power supply, adapting to any application-related need. They can be mixed with one another or interlocked with two priority levels. The level of the microphone signal and of the warning tone ("Chime" generator included) can be adjusted via the rear panel.

B711-G

Pre-amplified base with a hold-down key (PTT, press to speak), a toggle button (LOCK) for long messages and a LED for signalling activation of the microphone.



B711/6-G

Pre-amplified base with six zone push-buttons and associated signalling LEDs, an All-Call key, a hold-down call key (PTT), a toggle key (LOCK) for long messages and a LED for signalling activation of the microphone.



No pre-amplified microphone bases

B701-MG

Non pre-amplified microphone base with a dynamic microphone, a gooseneck stem and a status LED. It has a hold-down key (PTT, press to speak) and a toggle push-button (LOCK) for long messages.



PRE-AMPLIFIED MICROPHONE BASE CONNECTIONS

PIN	AUDIO IN/OUT	ZONES 1-6
1	Audio +	Zone 1
2	Audio -	Zone 2
3	GND	Zone 3
4	Prec. IN/OUT	Zone 4
5	N. C.	Zone 5
6	+ Vdc	+ Vdc
7	Serial +	Zone 6
8	Serial -	GND
Shield	GND	GND

Each base is equipped with RJ45 sockets for direct connection by means of SFTP Cat 5 shielded cables (AUDIO IN and AUDIO OUT). The B711/6-G station also has a ZONES 1 to 6 socket for controlling the switching relays for the zones and/or for activating alarms. The connectors must be of the shielded RJ45 type.

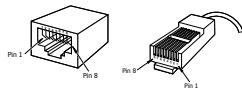

NO PRE-AMPLIFIED MICROPHONE BASE CONNECTIONS

Each base is supplied with a 5-metre long balanced shielded cable fitted with an XLR plug and terminals for activating microphone precedence in PASO amplifiers.

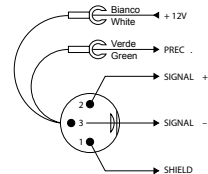

PMB range • Digital microphone bases

Microphone bases

This model features an electret microphone and a stem with a flexible part near the base. It can be run on a central and/or local power supply (18 to 36 VDC). The following can be configured from the keypad: setting of the address (up to 31), priority level (up to 7), adjustment of microphone sensitivity, programming of zone keys and of the All-Call key (ALL), activation of the speech filter for improved intelligibility.

PMB106-G

Pre-amplified station with 6 programmable zone push-buttons and associated indicator LEDs, an All-Call key, a hold-down call key (PTT), a toggle button (LOCK) for long messages and a microphone activated and busy LED.



PMB112-G

Pre-amplified station with 12 programmable zone push-buttons and associated indicator LEDs, an All-Call key, a hold-down call key (PTT), a toggle button (LOCK) for long messages and a microphone activated and busy LED.



Expansion module

PMB112-EG

Expansion keypad for PMB112-G microphone stations, 12 programmable zone push-buttons, signalling LEDs, All-Call key. It is possible to connect up to two units in cascade fashion.



CONNECTIONS

PMB microphone bases are equipped with RJ45 sockets for direct connection by means of SFTP Cat 5 shielded cables.

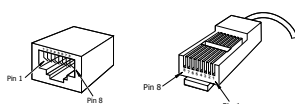

PIN	AUDIO IN/OUT
1	Audio +
2	Audio -
3	GND
4	Not connected
5	Not connected
6	+ Vdc
7	Serial +
8	Serial -
Shield	GND

All the connectors must be shielded RJ45 type.

B53 range • Special applications

B53-C

Pre-amplified microphone case with a dynamic microphone featuring a gooseneck stem, a hold-down key for making calls and LED that lights up when a call is in progress. Its limited width makes it suitable for fixing to surfaces on which there is not much room (e.g. supermarket cash desks). Adjustable sensitivity and line output signal level. 1.5-metre long cable with weldable wires included in the supply.





MODEL	B701-MG	B711-G	B711/6 -G	PMB106-G	PMB112-G	B53-C
Characteristics	Dynamic microphone, general call push-button (PTT), automatic release or one switch type (LOCK)	Electret microphone, general call push-button (PTT), automatic release or one switch type (LOCK), dynamics compressor			Dynamic microphone, general call push-button (PTT), dynamics compressor	
Zone selection	1	6 + ALL			12 + ALL	1
Sensitivity / Impedance	1,8 mV/Pa / 500 Ω	Trimmer adjustment		Keyboard adjustment		Trimmer adjustment
frequency response	100 ÷ 12.000 Hz	100 ÷ 15.000 Hz		100 ÷ 14.000 Hz		50 ÷ 14.000 Hz
Output audio level	-	1,2 Vrms (balanced)		2,2 V max		2 V RMS (unbalanced)
Connections	5 m cable with XLR plug e 2 terminals for activating microphone precedence	RJ45 (AUDIO OUT)	RJ45 (AUDIO OUT e ZONE 1÷6)		RJ45 (IN/OUT)	Solder wires
Mains power supply	12 Vdc (precedence)	12 / 24 Vdc		18 /36 Vdc		11÷28 Vdc
Consumption	LED 8 mA (12 V)	45 mA	60 mA	16 mA	22 mA	30 mA
Finish	Light grey ABS structure					Black metal
Dimensions (W x H x D)	116 x 440 x 200 mm		116 x 416 x 200 mm			47 x 454 x 188 mm
Weight	0,88 kg		0,8 kg		0,6 kg	0,8 kg
Accessories	AC700 fixing mounting kit for B700 and PMB microphone station range					-

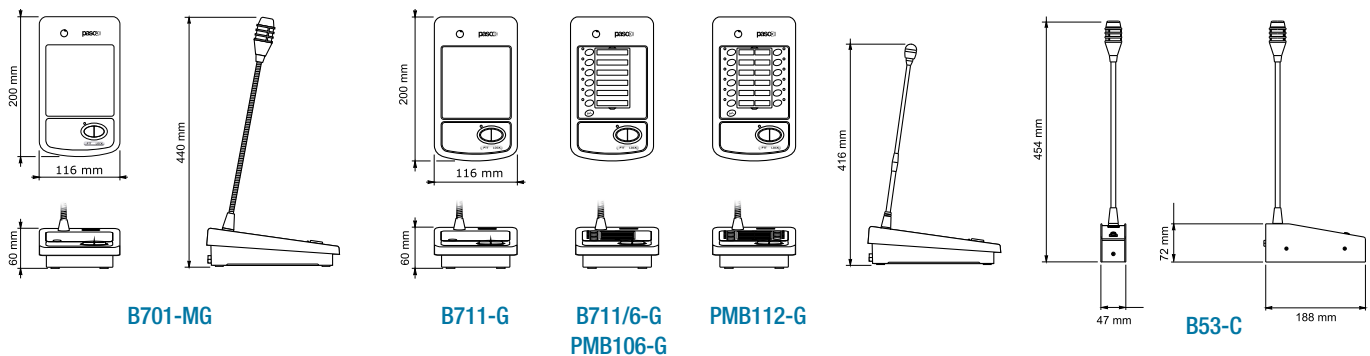

Compatibility between PASO Microphone/Consoles and Amplifiers

MODEL	M1-NC M936 M976	MC102 MC250 MC260 MC265	B701-MG	B53-C	B711-G	B711/6-G	PMB106-G PMB112-G
Type	Dynamic microphone	Electret microphone (Phantom power supply)	Base with dynamic microphone (+12 V precedence)	Pre-amplified base with dynamic microphone (+12 V precedence)	Pre-amplified base (+12 V precedence)		Pre-amplified base (RS485 serial data)
Connection	XLR		XLR + 2 precedence wires	Wires	RJ45 sockets (SFTP CAT 5 shielded cables and shielded connectors)		
Functionality	Mixing		Mixing or with priority if connecting precedence	With priority		With priority and zone selection keys	
Compatibility with audio inputs of PASO amplifier/control units							
AX3504	MIC 2		MIC 2 + Precedence	TEL/EMERG + Precedence (wires connection)		-	-
AX3506, AX3512	MIC 1÷4		MIC 1÷4 + Precedence	TEL/EMERG + Precedence (wires connection)	IN UNITS	-	-
AX6000 range	MIC 1÷5		MIC 1÷5 + Precedence	TEL/EMERG + Precedence (wires connection)		-	IN UNITS
PA6000 range	MIC 1÷5		MIC 1÷5 + Precedence	TEL/EMERG + Precedence (wires connection)		-	IN UNITS
PA1000 range	MIC 1÷3		MIC 1÷3 + Precedence	MIC 1÷3 + Precedence (wires connection and XLR)		-	-
AW5600 range	-	-	-	TEL/EMERG + Precedence (wires connection)	IN UNITS	-	-
MX5539	MIC 2÷9		MIC 2÷9 (no precedence)	-	-	-	-
P8036	-	-	-	BASE IN with precedence (wires connection)		BASE IN with prec. + ZONE (wires connection)	
P8136	-	-	-	Using ACIO8136 module (wires connection)			MASTER UNITS and LOCAL UNITS
P8236	-	-	-	Using ACIO8136 module (wires connection)			LOCAL UNITS
Connection accessories							
Extension cables	CV15, CV24		CV15, CV24 + 2 wires for precedence	-	CV20xx cable range		
Cable rolls	31/2-100		31/84-100	31/65-250	31/142-100		

Wireless microphones and accessories



Wireless microphones UHF multi-channel

MA855/R850A Hand-held wireless microphone unit



The **MA855/R850A** and **MA853/R850A** kits are wireless microphone systems of the Diversity UHF type featuring high performance levels and PLL technology. They enable selection of 120 channels for maximum flexibility. The "Diversity" technology of the receiver and the microphone antenna ensure an exceptionally broad range for maximum reliability of the signal and freedom of movement.

Both transmitters (MA855A with a handgrip and MA853A pocket model) have a handy mute function, an LCD display, a keypad lock and a battery-status indicator.

The R850A receiver, which has its own power supply, is equipped with an automatic scanning system for identifying the frequency of the microphone, a large LCD display, an RF/AF level measuring device and a squelch circuit that enables any interferences present in the surrounding environment to be eliminated.

ACCESSORIES

AC850 Support for rack mounting of one R850A receiver (1 U)

AC852 Support for rack mounting of two R850A receivers (1 U)

AC855 Battery charger for MA855A and MA853A transmitters

MA853/R850A Lavalier wireless microphone kit

MODEL	MA855/R850A	MA853/R850A
Characteristics	- Hand-held wireless microphone with dynamic capsule - 120 channels	- Pocket wireless microphone with electret capsule - 120 channels
Carrier frequency	638 ÷ 662 MHz (UHF)	
RF sensitivity	-100 dBm/30dB	
Frequency response	50 ÷ 15.000 Hz	
Receiver output level	Balanced XLR, 25 mV Unbalanced Jack 6,3 mm, 750 mV	
Operating range (line of sight)	100 m	100 m
Mains power supply	- R850A receiver: 12 Vdc/ 500 mA - MA855A or MA853A transmitter: AA (2 off) or rechargeable NiMH batteries	
Supplied accessories	AC/DC power supply unit, audio LF cable, 2 antennas, color ID caps	AC/DC power supply unit, audio LF cable, 2 antennas, windscreen
19" rack mounting (modular units)	AC850 optional support for one R850A receiver (1 U) AC852 optional support for two R850A receiver (1 U)	
Dimensions (W x H x D)	MA855A transmitter: 51 x 278 mm R850A receiver: 210 x 46 x 159 mm	MA853A transmitter: 70 x 98 x 23 mm R850A receiver: 210 x 46 x 159 mm
Weight	MA855A transmitter: 240 g R850A receiver: 0,95 kg	MA853A transmitter: 90 g R850A receiver: 0,95 kg

Accessories for microphones and microphone bases



S1
Jointed microphone support, can be screwed onto telescopic table-top or floor bases.



S10
Same features as the S1, with vibrationdamping elastic body.



S8
Jointed support for microphones and wireless microphones with spring-type seal.



B160
Table-top base for MC30-GN microphones, complete with shielded cable
(L) 100 cm. Size: Ø 4.5 cm; (H) 4.2 cm.



B60-N
Chromium-plated ring-nut for table-top mounting, black. Provisions for using F5-N or F11-C flexible stems. Dimensions: Ø 4.5 cm.



B12
Cast-iron table-top base, black, for F5-N and F11-C flexible stems.



B70-N
Chromium-plated ring-nut for table-top mounting, black. Provisions for using F5-N or F11-C flexible stems. Dimensions: Ø 6.5 cm.



27/59
Adaptor for screwing supports S1 and S10 onto the pins of telescopic bases with M12 x 1 or 3/8" threads.





B13-N

B13-N

Floor stand, complete with telescopic rod and folding tripod. With adjustable height and microphone boom.
 Height: 92÷152 cm
 Base spread: 70 cm
 Weight: 2.5 kg

B20-N

Floor stand with circular cast metal supporting structure. Telescopic rod with adjustable height and painted black tubular metal.
 Height: 95÷175 cm
 Base width: 30 cm
 Weight: 4 kg



F5-N

Flexible support with threaded (16x1) male and female ends. To be used between the B12, B60-N and B70 and the S1, S8 and S10 supports. Length 40 cm. Dia 14 mm. Black, without cable.



B116-B

Table-top base in black cast-iron, with chromiumplated telescopic rod, adjustable from 37 to 60 cm. For microphone supports S1, S8 and S10.



MC30-GN

Electret microphone with a cardioid polar response and flexible support. It's equipped with a 5-poles DIN male connector. It is possible to use with AC14-B preamplifier card.
 Length: 44 cm
 Frequency response: 100÷20000 Hz
 Sensitivity: -67 dBV/ μ bar. Impedance: 680 Ω

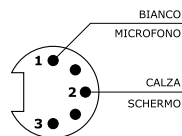

F11-C

Flexible support, with microphone XLR socket, balanced shielded cable (1.1 m) with XLR plug. L.: 40 cm. Dia.: 14 mm.



AC14-B

Pre-amplifier module for dynamic and electret microphones. Screw connectors. Suitable to install into standard electric box (e.g. 27/901). Balanced audio output. Sensitivity and output signal level can be adjusted. It has provisions for connection to a LED and a push-button activation.
 Power supply: 12/24 Vdc
 Dimensions: 74 x 50 x 10 mm

CV2002	CAT5e SF/UTP shielded cable, length 2 m, with RJ45 connectors
CV2005	CAT5e SF/UTP shielded cable, length 5 m, with RJ45 connectors
CV2010	CAT5e SF/UTP shielded cable, length 10 m, with RJ45 connectors
31/142-100	CAT5e SF/UTP shielded cable, 100 m roll
31/2 -100	Shielded microphone cable (2 wires + shield), 100 m roll
31/84-100	Shielded cable (2 wires and 2 wires + shield), 100 m roll
31/65-250	CEI 20-22 II cable, (3 wires + 1 shielded wire), 250 m roll
CV15	5 m microphone extension cable, complete with male and female XLR connectors
CV24	10 m microphone extension cable, complete with male and female XLR connectors
CV27	1 m shielded cable, complete with 5-pole DIN connectors
CV28	1 m shielded cable, complete with 5-pole DIN and phono RCA connectors
CV33	1,5 m shielded cable, complete with phono RCA connectors
CV37	1,5 m cable DB9/CAT5 adaptor (PMB106-G and PMB112-G microphone station units)

Speaker units

Thanks to the variety of models and characteristics of **PASO** speaker units, it is easy to find just the right model and the most suitable for each and every application and/or environment.



Wall-mounting speakers



C94 range



C94/30-T



C94/30-TN



C94/15-T



C94/15-TN

C94 sound speakers have been created and designed in Italy. Their exclusive and elegant design allows the loudspeakers to be used for any installations and environment, keeping the same high quality sound throughout. The C94 range, made of ABS with a front metal grille, utilizes a compact two-way system guaranteeing high performances, wide dynamics, high fidelity sound reproduction and high voice intelligibility. C94 speakers are equipped with an exclusive fully adjustable support bracket for easy installation, to cut costs and save installation time. The bracket may be attached to the wall prior to installing the loudspeaker and is provided with a safety cable. Connection to the loudspeakers is via plug in "Euroblock" connector and adjustment of loudspeaker output is made via screwdriver adjustable switch.

C94/30-T 30 W, two-way, bass-reflex, white

C94/30-TN 30 W, two-way, bass-reflex, black

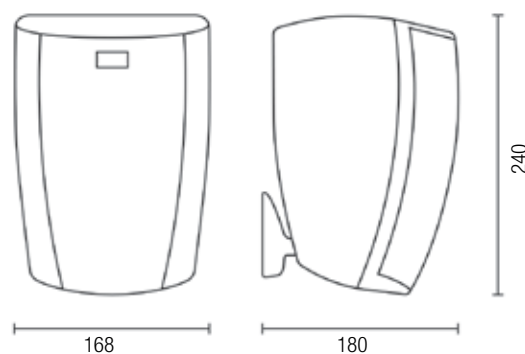

C94/15-T 15 W, two-way, bass-reflex, white

C94/15-TN 15 W, two-way, bass-reflex, black

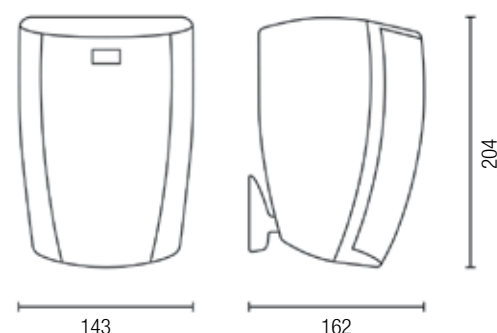

MODEL	C94/15-T	C94/15-TN	C94/30-T	C94/30-TN
Rated power	15 W (30 W / 8 Ω)		30 W (60 W / 8 Ω)	
Adjustable power	15 / 7,5 / 4 / 2 W		30 / 20 / 15 / 10 W	
Impedance	8 Ω			
Characteristics	ABS body, metal front grille			
Loudspeakers	1Wf + 1Tw (bass-reflex)			
Sound pressure SPL (Pnom/1m)	100 dB		106 dB	
Efficiency (1W/1m)	85 dB		87,5 dB	
Frequency response	100 ÷ 15.000 Hz		85 ÷ 15.000 Hz	
Dispersion angle @2kHz	120°		100°	
Mounting	Wall mounting bracket (supplied)			
Colour	White (RAL 9016)	Black	White (RAL 9016)	Black
Dimensions (W x H x D)	143 x 204 x 162 mm		168 x 240 x 180 mm	
Weight	1,5 kg		2,3 kg	

Wall-mounting speakers

C95 "ONDA" range • Design by Lucci and Orlandini



AC915

The speaker units of the "ONDA" range feature an original concept and high technical and aesthetic quality. They are available in the standard colours "Quartz" White and "Goldmetal" Black. The support included in the supply enables them to be fixed either on a wall or on a ceiling. The optional **AC915** support can be used to rest a speaker unit on a surface. The quality of the project makes it a product for universal use, meeting any need for sound-broadcasting in interiors. Excellent reproduction of both speech and music.

C95/20-T 20 W, 100 V transformer, white

C95/40-T 40 W, 100 V transformer, white

C95/40 40 W, 8 Ω, white

C95/20-TN 20 W, 100 V transformer, black

C95/40-TN 40 W, 100 V transformer, black

C95/40-N 40 W, 8 Ω, black

C33 "FLAT" range

Flat two-way speaker unit for wall-mounting, in white ABS with metal front grille. Elegant and discreet design with good reproduction of both speech and music. Suitable for any indoor environment. Wall-mounting is quick and easy. A transformer for connecting to constant-voltage lines is included in the supply.

C33/10-T 10 W, two-way, "FLAT"

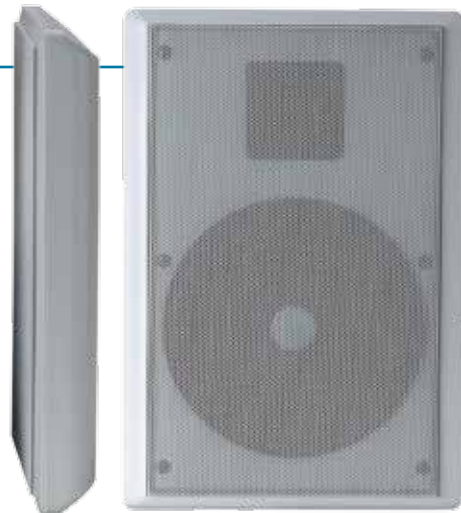

MODEL	C95/40-T	C95/40	C95/20-T	C33/10-T
Rated power	40 W	40 W	20 W	10 W
Adjustable power	40 / 20 / 10 / 5 W	-	20 / 10 / 5 / 2,5 W	10 / 5 W
Impedance	-	8 Ω	-	-
Characteristics	ABS body and front grille			ABS body, metal front grille
Loudspeakers	1Wf + 1Tw		1 broadband	1 Wf + 1 Tw
Sound pressure SPL (Pnom/1m)	103 dB		101 dB	99 dB
Efficiency (1W/1m)	87 dB		88 dB	89 dB
Frequency response	100 ÷ 20.000 Hz		130 ÷ 20.000 Hz	200 ÷ 18.000 Hz
Dispersion angle @2kHz	130°		150°	90°
Mounting	Wall or ceiling mounting with support included / Optional AC915 support to position on a shelf			Screw
Colour	White (Black all models with the suffix -TN and -N)			White
Dimensions (W x H x D)	320 x 215 x 93 mm			185 x 272 x 46 mm
Weight	2,8 kg	2,2 kg	2,1 kg	0,92 kg



C36 "CANDY" range • ABS UL 94-V0



C36/6-EN Mono-directional, 6 W, EN 54-24, ABS UL94-V0



C36/6-T Mono-directional, 6 W, ABS UL94-V0



C36/6-2T Bi-directional, 3+3 W

The speaker units of the **C36** range, featuring a refined and modern design and ideal for both background music and speech, have been designed specifically for schools, hospitals, waiting rooms, hotels, shops, offices and restaurants. They can be either wall-mounted or ceiling-mounted. The housing is made of white self-extinguishing ABS (UL94-V0) with a metal front grille. Each unit has a ceramic terminal block and a thermal fuse.

Models **C36/6-EN** were developed specifically for use in emergency and evacuation systems (VES). They are certified according to **EN 54-24:2008** (certif. no. **0068-CPD-033/2013**) since each unit is equipped with a ceramic terminal block and a thermal fuse to guarantee safety of the line connecting the loudspeakers in the event that one or more of the speaker units connected to it are damaged by fire.

C36/6-T and **C36/6-EN** speaker units each have a loudspeaker with a transformer for constant-voltage lines (50, 70 and 100 V); the output power is adjustable (6, 3 or 1.5 W).

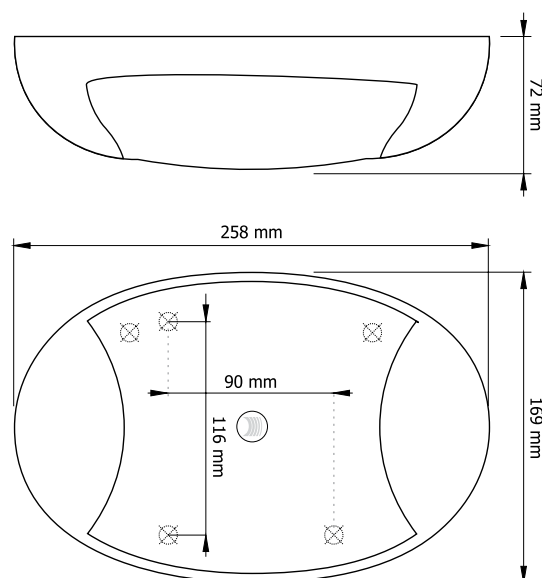

Two-directional **C36/6-2T** speaker units are suitable in particular for installing in transit areas and corridors. Each unit has two 3 W loudspeakers, again with a transformer for constant-voltage lines (50, 70 and 100V) and the output power is adjustable to 6, 3 or 1.5 W.

MODEL	C36/6-T	C36/6-EN	C36/6-2T
Rated power	6 W		6 W (3+3 W)
Adjustable power		6 / 3 / 1,5 W	
Characteristics	UL94-V0 ABS body, metal front grille		
Loudspeakers	1 broadband		2 broadband
Sound pressure SPL (P _{nom} /1m)	100 dB		93 dB
Efficiency (1W/1m)	92 dB		86 dB
Frequency response	180 ÷ 10.000 Hz		130 ÷ 14.000 Hz
Dispersion angle @2kHz	110°		150° (@4kHz)
Mounting	Wall or ceiling mounting with screws		
Colour	White		
Dimensions (W x H x D)	258 x 169 x 72 mm		
Weight	0,8 kg		0,93 kg

Wall-mounting speakers



C37 range • Metal



The **C37/6-EN** speaker unit is certified for compliance with **EN 54-24:2008** (certif. no. **0068-CPD-033/2013**), and was developed specifically for use in a vast range of applications. It can be wall or ceiling-mounted. It has a particularly tough housing made of metal sheeting, with a matte white powder paint finish. It has a ceramic terminal block and a thermal fuse to ensure safety of the line connecting the loudspeakers in the event that one or more of the speaker units connected to it are damaged by fire.

C37/6-EN 6 W, EN 54-24 certified, metal

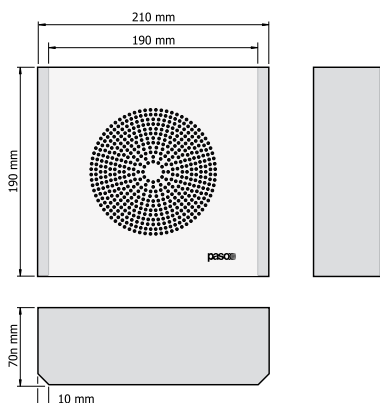

C34 range

The speaker units of the **C34** range for interiors consist of a shockproof plastic housing with a white UV-stabilised finish, fitted with a metal grille of the same colour.

These units have loudspeakers with a broad frequency response for excellent reproduction of background music and speech. Both models have transformers for constant-voltage lines. The **C34-RB** speaker unit also has an external step-by-step volume control.

C34-TB 6 W, wall-mounting speaker

C34-RB 6 W, with volume control



MODEL	C37/6-EN	C34-TB	C34-RB
Rated power		6 W	
Adjustable power		6 / 3 / 1,5 W	6 / 3 / 1,5 / 0,75 / 0,3 W
Characteristics	Metal	UV-stabilised shockproof plastic housing, metal front grille	
Loudspeakers		1 broadband	
Sound pressure SPL (P _{nom} /1m)	99 dB		100 dB
Efficiency (1W/1m)	91 dB		93 dB
Frequency response	150 ÷ 15.000 Hz		180 ÷ 16.000 Hz
Dispersion angle @2kHz	90°		110°
Mounting	Wall or ceiling mounting with screws		Screws
Colour	White		White
Dimensions (W x H x D)	210 x 190 x 70 mm		218 x 216 x 120 mm
Weight	1,6 kg		1,24 kg



Flush-mounting speakers

C41 range



Rectangular two-way speaker units for flush-mounting on walls or in false ceilings. Their performance is excellent for reproducing music and speech. They are ideal in refined environments such as wellbeing centres, hotels and conference halls. They are white and made of ABS with a metal front grille. Each speaker unit has a transformer for connection to constant-voltage lines. They are equipped with special hooks for enabling direct installation in false ceilings. For easy flush-mounting in a wall, (optional) **AC941** boxes should be used.

C41/10-HF 10 W, two-way, flush-mounting (wall/false ceiling)

ACCESSORIES

AC941 Wall-mounting box (210 x 155 x 70 mm)

C44 range

The ideal application for speaker units of the **C44** range is in hospitals, hotels, offices, schools, shops or anywhere where flush-mounting and a discreet and elegant appearance are required. Each unit is made of self-extinguishing plastic material UL94-VO with a metal front grille. Two models are available, with an output power of 6 and 20 W with a line transformer respectively. The (optional) **AC91** box for flush-mounting makes wall-mounting easy and quick.



Models **C44/12-EN** were designed specifically for use in emergency and evacuation systems (VES). Each unit has a ceramic terminal block and a thermal fuse. They are certified for compliance with **EN 54-24:2008**. The metal box for flush-mounting makes this operation easy and quick, with spring-mounted hooks (included in the supply).



C44/6-TB 6 W flush-mounting

C44/20-TB 20 W flush-mounting

ACCESSORIES

AC901 Wall-mounting box (162 x 276 x 78 mm)

C44/12-EN 12 W, EN 54-24 certified

MODEL	C44/6-TB	C44/20-TB	C44/12-EN	C41/10-HF
Rated power	6 W	20 W	12 W	10 W
Adjustable power	6 / 3 / 1,5 W	20 / 10 / 5 / 2,5 W	12 / 6 / 3 W	-
Characteristics	UL94-VO ABS body, metal front grille			ABS body, metal front grille
Loudspeakers	1 broadband	1 two-cone broadband	1 broadband	1 Wf + 1 Tw
Sound pressure SPL (Pnom/1m)	97 dB	103 dB	99 dB	98 dB
Efficiency (1W/1m)	90 dB	90 dB	89 dB	88 dB
Frequency response	150 - 13.000 Hz	100 ÷ 15.000 Hz	150 ÷ 15.000 Hz	120 ÷ 20.000 Hz
Dispersion angle @2kHz	120°		120°	170°
Mounting	AC901 optional box for flush-mounting		Flush-mounting wall/ceiling box	False ceiling (hole: 118 x 193 mm) AC941 box for flush-mounting
Colour	White			
Dimensions (W x H x D)	165 x 280 x 70 mm		165 x 280 x 90 mm	148 x 222 x 68 mm
Weight	0,83 kg	1,38 kg	2 kg	1,3 kg

Sound projectors Aluminium



C86 range • Vandal-proof housing



The vandal-proof sound projectors of the **C86** range feature a grey aluminium housing and a yellow-galvanised front grille, tropicalised and stove-enamelled. Thanks to the particularly tough and sealed design, class of protection IP65, this range is especially suitable for use in particularly difficult environmental conditions.

They have wide-band loudspeakers featuring a high level of acoustic efficiency for excellent reproduction of both voice and music. Each unit is supplied with a swivelling fixing bracket that slides along the housing and a transformer for 100/70/50 V constant-voltage lines with an output power adjustable to 20-10-5 W.

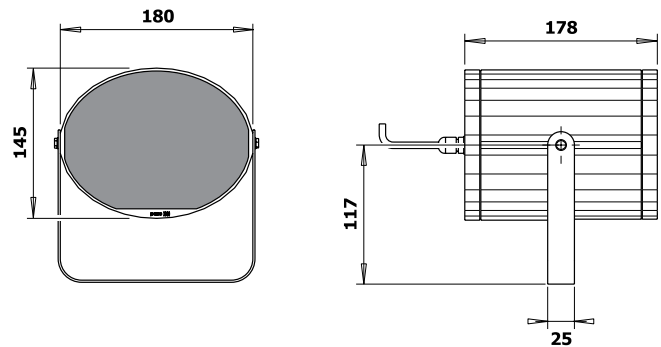

C86/20-TW 20 W, aluminium vandal-proof housing, IP65

C86/20-EN 20 W, EN54-24 certified

The models with the suffix **-EN** were designed specifically for use in emergency and evacuation systems (VES). Each unit has its own thermal fuse that excludes the loudspeaker in the event of overheating plus a flame-proof connecting cable (80 cm in length); they are certified for compliance with **EN 54-24:2008** (cert. No. **0068-PD-033/2013**). The **C86/20-2TW** and **C86/20-2EN** two-directional sound projectors are particularly suitable for installation in transit areas or corridors.

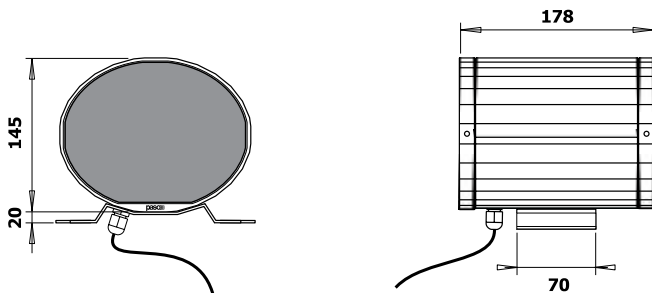

C86/20-2TW Bi-directional 10+10 W, vandal-proof housing, IP65

C86/20-2EN Bi-directional 10+10 W, EN54-24 certified

MODEL	C86/20-TW	C86/20-EN	C86/20-2TW	C86/20-2EN
Rated power	20 W		20 W (10+10 W)	
Adjustable power	20 / 10 / 5 W			
Characteristics	Aluminium housing and a stainless steel front grille			
Loudspeakers	1 broadband		2 broadband	
Sound pressure SPL (P _{nom} /1m)	105 dB		100 dB	
Efficiency (1W/1m)	92 dB		87 dB	
Frequency response	150 ÷ 15.000 Hz			
Dispersion angle @2kHz	100°		2 x 110°	
Protection degree	IP 65			
Mounting	Swivelling bracket and connecting cable	Swivelling bracket and flame-proof connecting cable	Swivelling bracket and connecting cable	Swivelling bracket and flame-proof connecting cable
Colour	Light grey body, black front grille			
Dimensions (W x H x D)	180 x 145 x 178 mm			
Weight	2,4 kg		2,85 kg	



C56 "SUNFLOWER" range



High acoustic efficiency and an original and modern design with an ellipse-shaped front are the particular features of this range of sound projectors, known as the **"SUNFLOWER"** model. The units of the **C56** range are available in versions with an output power of 6 W or 12 W RMS, with a white self-extinguishing ABS structure and a transformer for constant-voltage lines. Thanks to their elegant finish, these speaker units are also suitable for places with special interior decoration requirements such as shops, boutiques, outlets, offices and so on. C56 sound projectors have guides that slide along the housing for securing the supporting bracket, thus ensuring handy mounting and correct positioning of the unit.

C56/6-T 6 W, ellipse-shaped sound projector

C56/12-TW 12 W, ellipse-shaped sound projector, IP55

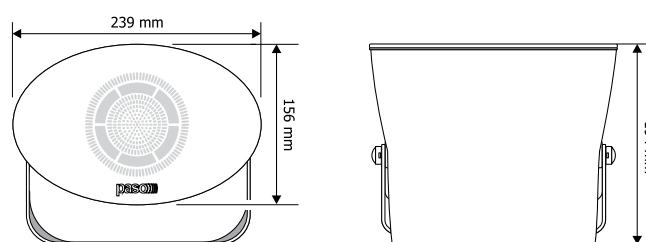

C46 range

The **C46-TW** sound projector with an output of 6 W features an excellent reproduction of sound and a compact size, with a loudspeaker treated to withstand moisture and suitable for use both indoors and out-of-doors provided the unit is sheltered from direct rain. It is made of pale grey shockproof polystyrene and has a line transformer that can be attenuated and a stainless steel swivelling bracket.

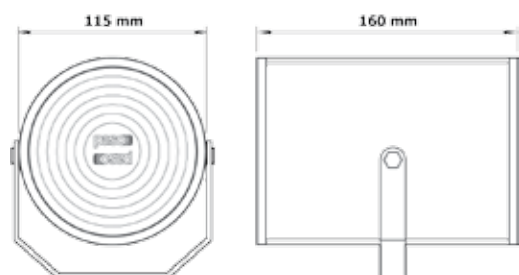

C46-TW 6 W, cylindrical sound projector, IP54

MODEL	C56/6-T	C56/12-TW	C46-TW
Rated power	6 W	12 W	6 W
Adjustable power	6 / 3 / 1,5 W	12 / 6 / 3 W	6 / 3 / 1,5 W
Characteristics	Self-extinguishing ABS		
Loudspeakers	1 broadband		
Sound pressure SPL (P _{nom} /1m)	96 dB	99 dB	98 dB
Efficiency (1W/1m)	88 dB		91 dB
Frequency response	160 ÷ 10.000 Hz	160 ÷ 12.000 Hz	140 ÷ 15.000 Hz
Dispersion angle @2kHz	90°		180°
Protection degree	IP 44	IP 55	IP 54
Mounting	Swivelling bracket and connecting cable		
Colour	White		Light grey
Dimensions (W x H x D)	239 x 156 x 194 mm		Ø 115 x 160 mm
Weight	1,5 kg	1,9 kg	1 kg

C55 range



Sound projectors are used mainly for directing the sound beam and concentrating it towards a specific area and can be used for innumerable applications. The **C55-TW** uses a wide-band loudspeaker featuring very high acoustic efficiency for excellent reproduction of both voice and music, and it is often used for broadcasting sound along main roads and promenades for tourists.

New Arbat Street in Moscow – sound-broadcasting system featuring C55-TW speaker units. This is the most important shopping street in Moscow. It is over a kilometre long and offers all sorts of bars, clubs and restaurants.

The sound projectors of the **C55** range are made of pale grey UV-stabilised ABS, self-extinguishing to UL94-V0. Each unit has a black chromium-plated stainless steel front grille. It has a constant-voltage line transformer and a swivelling fixing bracket that slides along the housing. This range is characterised by excellent reproduction of both music and speech. There are models featuring a high sound pressure to ensure a high acoustic performance. Models are available for installation in covered areas (**C55**) as well as other sealed units (**C55-S**, **C55-TW**) that can also be installed outside.

C55 20 W sound projector

C55-S 20 W sound projector, IP66

C55-TW 40 W sound projector, IP65

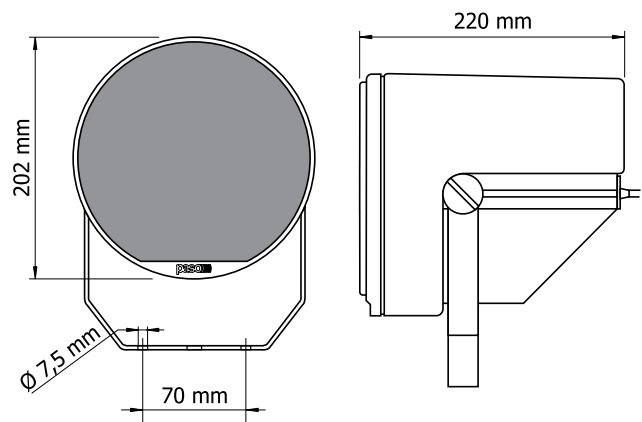

MODEL	C55	C55-S	C55-TW
Rated power	20 W		40 W
Adjustable power	20 / 10 / 5 W		40 / 20 / 10 / 5 W - 16 Ω
Characteristics	Self-extinguishing ABS body, stainless steel front grille		
Loudspeakers	1 broadband		
Sound pressure SPL (P _{nom} /1m)	102 dB	100 dB	103 dB
Efficiency (1W/1m)	89 dB	87 dB	
Frequency response	150 ÷ 12.000 Hz	150 ÷ 6.500 Hz	100 ÷ 19.000 Hz
Dispersion angle @2kHz	70°		110°
Protection degree	IP 44	IP 66	IP 65
Mounting	Swivelling bracket and connecting cable		
Colour	Light grey body, black front grille		
Dimensions (W x H x D)	Ø 200 x 220 mm		
Weight	3 kg		



C48 range



C48/12-EN 12 W, EN 54-24 certified, mono-directional

C48/6-2EN 6+6 W, EN 54-24 certified, bi-directional



C48/12-TW 12 W, mono-directional sound projector, IP65

C48/12-2TW 12+12 W, bi-directional sound projector, IP65

Thanks to the use of excellent wide-band loudspeakers, the sound projectors of the **C48** range are suitable for reproducing both music and speech, and can be used both indoors and outside. Contained in a cylindrical structure made of white self-extinguishing ABS (to UL94-V0), each unit is supplied with a line transformer and with a swivelling bracket to facilitate wall and/or ceiling mounting. Designed to obtain sound emission with very good directivity, they are suitable mainly for installation in transit areas, corridors and in particularly large areas.

The models with the suffix **-EN** were designed specifically for use in emergency and evacuation systems (VES). Each unit has its own thermal fuse that excludes the loudspeaker in the event of overheating plus a flame-proof connecting cable (80 cm in length); they are certified for compliance with **EN 54-24:2008** (cert. No. **0068-PD-033/2013**). The C86/20-2TW and C86/20-2EN two-directional sound projectors are particularly suitable for installation in transit areas or corridors.

The sound projectors with the suffix **-TW** are watertight, class of protection IP65, and can therefore also be used in open-air installations.

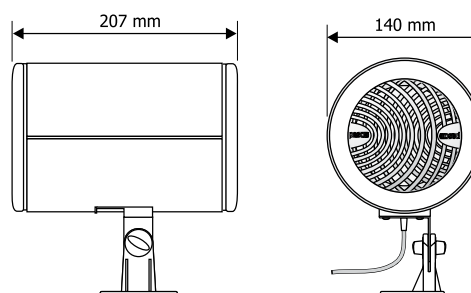

C48/6-2EN • C48/12-2TW

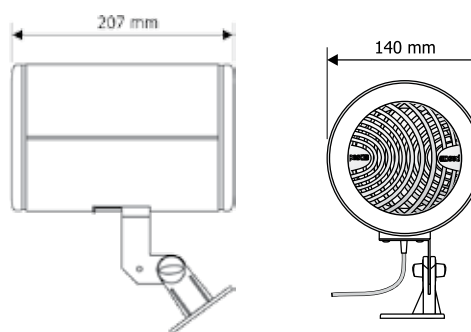

C48/12-EN • C48/12-TW

MODEL	C48/12-TW	C48/12-EN	C48/12-2TW	C48/6-2EN
Rated power	12 W		24 W (12+12 W)	12 W (6+6 W)
Adjustable power	12 / 6 / 3 W		24 / 12 / 6 / 3 W	12 / 6 / 3 W
Characteristics	UL94-V0 ABS			
Loudspeakers	1 broadband		2 broadband	
Sound pressure SPL (P _{nom} /1m)	99 dB	101 dB	98 dB (*)	99 dB
Efficiency (1W/1m)	88 dB	90 dB	87 dB (*)	88 dB
Frequency response	180 ÷ 15.000 Hz	170 ÷ 13.000 Hz	170 ÷ 12.000 Hz	170 ÷ 14.000 Hz
Dispersion angle @2kHz	160°	100°	140° (*)	120°
Protection degree	IP 44		IP 65	IP 44
Mounting	Swivelling bracket and connecting cable	Swivelling bracket and flame-proof connecting cable	Swivelling bracket and connecting cable	Swivelling bracket and flame-proof connecting cable
Colour	White			
Dimensions (W x H x D)	Ø 140 x 207 mm			
Weight	1,7 kg		2,2 kg	2 kg

Sound columns

C400 "SLIM LINE" range



A compact size and high acoustic performance are the typical features of the sound columns of the **C400** range. Each column consists of a weight-bearing structure made of extruded aluminium painted pale grey, a solid front grille and sealed shockproof end panels. Each column has a swivelling support for quick securing to a wall and a constant-voltage line transformer. Connections to the various sockets are made via the cable coming out of the column. A pair of sliding guides running along the whole height of the rear of the column enables the S4-B swivelling support included in the supply to be positioned so as to simplify mounting.

The acoustic properties of this sound column are characterised by great intelligibility of speech and excellent reproduction of music, in addition to the limited size. This means that they are the ideal choice for places that are difficult from the acoustic point of view, where uniform distribution of the sound and excellent directivity are required.

Model **C450-TW** is also suitable for outdoor use in poor weather conditions.

C420-T Sound column, 20 W

C430-T Sound column, 30 W

C440-T Sound column, 40 W

C450-TW Sound column, 50 W, IP66



Using an M6x20 grub screw, as shown in the figure, it is possible to mount two sound columns (of the same type) with one on top of the other; this gives rise to a single sound column of twice the height, with an opening angle on the vertical plan that is further reduced.

C402-T 6 W, two-way speaker



In the **C400** range, the two-way model **C402-T** should be pointed out. It features a compact size and high-quality reproduction. It has the same structure as the other models of the C400 range but a swivelling bracket for fixing it is included in the supply.

ACCESSORIES

S4-B Wall-mounting jointed support



The **S4-B** jointed support is included in the supply. This enables the column to be secured to a wall and then pointed in the required direction.

MODEL	C402-T	C420-T	C430-T	C440-T	C450-TW
Rated power	6 W	20 W	30 W	40 W	50 W
Adjustable power	6 / 3 / 1,5 W	20 / 10 / 5 W	30 / 15 / 7,5 W	40 / 20 / 10 W	50 / 25 / 12,5 W
Loudspeakers	1 Wf + 1 Tw	4 Wf + 1 Tw	6 Wf + 1 Tw	7 Wf + 2 Tw	4 Wf + 1 Tw
Characteristics	Aluminium structure				
Sound pressure SPL (P _{nom} /1m)	101 dB	105 dB	110 dB		109 dB
Efficiency (1W/1m)	94 dB	92 dB	95 dB	94 dB	92 dB
Frequency response	200 ÷ 18.000 Hz	180 ÷ 16.000 Hz		150 ÷ 14.000 Hz	120 ÷ 15.000 Hz
Dispersion angle @2kHz	Or. 210° - Ver. 140°	Or. 160° - Ver. 30°	Or. 160° - Ver. 20°	Or. 160° - Ver. 13°	Or. 160° - Ver. 30°
Protection degree	IP 44	IP 44	IP 44	IP 44	IP 66
Mounting	Supplied bracket	S4-B supplied jointed support			
Colour	Light grey				
Dimensions (W x H x D)	95 x 182 x 78 mm	95 x 520 x 80 mm	95 x 725 x 80 mm	95 x 890 x 80 mm	95 x 520 x 80 mm
Weight	1,2 kg	3,5 kg	4,8 kg	5,65 kg	2,3 kg



C7200-EN sound column



The **C7200-EN** sound column is extremely compact and elegant, and features a refined and functional design. Its uncompromising quality enables it to meet the requirements of the most demanding installations. The speaker unit is equipped with six 4" woofers and four 1" tweeters. The cylindrical wave-front of this sound column makes for the pleasant effect of a very powerful and precise forward-projected sound, with none of the typical reverberation of conventional speaker units that excite reflections within the environment, directing acoustic energy where it is not needed. The very narrow and elongated shape enables this sound column to fit into any environment in a very discreet manner that is not invasive at all.

The C7200-EN sound column is a particular acoustic speaker unit designed for obtaining very precise directivity characteristics. It is ideal for installing in environments subject to reverberation, increasing the ratio of direct sound to reflected sound so as to improve the intelligibility of both music and speech. It has a powder-painted extruded aluminium load-bearing structure. The length of the line array can be extended by adding other modules so as to increase the SPL and restrict the vertical radiation lobe.

The C7200-EN column can be configured either in the constant-impedance mode or in the constant voltage mode by means of a line transformer. There is an optional accessory, the **AC7200**, for wall-mounting the C7200-EN column.



The C7200-EN sound column was developed for use in emergency and evacuation systems (VES); a thermal fuse that excludes the loudspeaker in the event of overheating and a flameproof connecting cable (90 cm in length) are included in the supply. This column is certified for compliance with EN 54-24:2008 (certificate no. **0068-CPR-058/2013**).

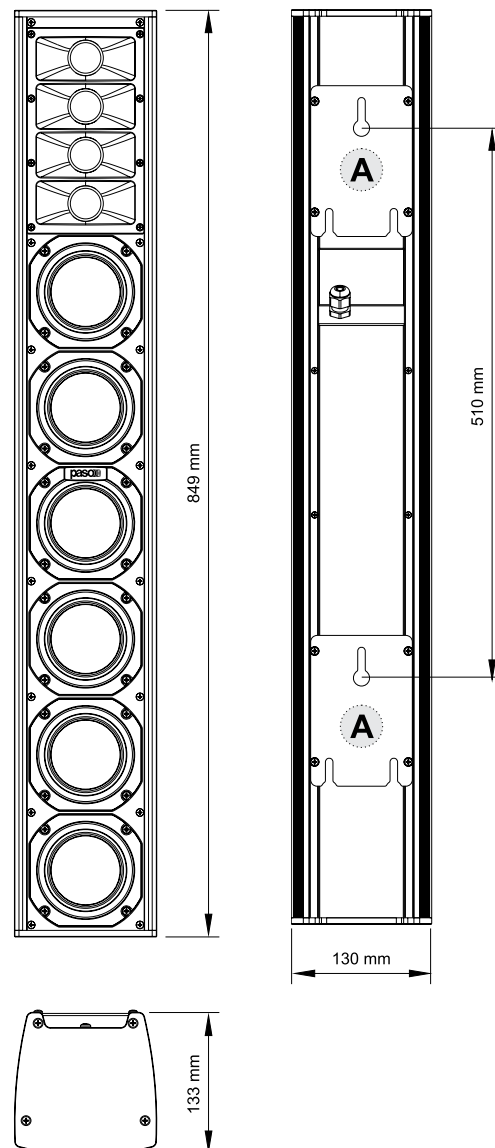

C7200-EN 100 W sound column, EN 54-24 certified

MODEL	C7200-EN
Rated power	100 W
Adjustable power	100 / 50 W - 8 Ω
Loudspeakers	6 Wf + 4 Tw
Characteristics	Aluminium structure
Sound pressure SPL (P _{nom} /1m)	110 dB
Efficiency (1W/1m)	91 dB
Frequency response	140 ÷ 20.000 Hz
Dispersion angle @2kHz	Or. 120° - Ver. 15°
Protection degree	IP 32
Mounting	AC7200 optional wall-mounting support
Colour	White RAL 9016
Dimensions (W x H x D)	130 x 849 x 133 mm
Weight	8 kg

ACCESSORIES

AC7200 Wall-mounting jointed support

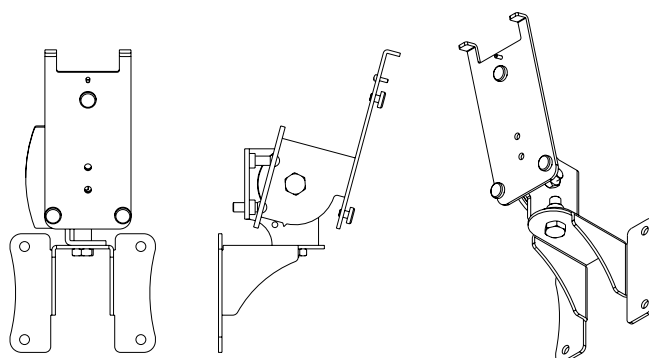

Horn speaker

With driver units

Metal horns



The horn speaker units of the **TRX20** range, featuring a watertight design and intended to guarantee the highest possible level of sound pressure, are particularly suitable for outdoor use even in difficult weather conditions. The housing is made of die-cast aluminium with stainless steel screws and brackets, while the horn is made of aluminium sheeting. Each model has a driver unit with a line transformer, a rear switch for selecting the operating power (five positions) and a terminal for correct connection to earth.

TRX20-TW 20 W round horn speaker, IP66

TRX20-V 20 W horn speaker, 4 kV insulation transformer

TRX20-EN 20 W horn speaker, EN54-24 certified

All models with the suffix **-EN** have been designed for use in safety and evacuation systems; each unit is equipped with a thermal fuse that isolates the speaker unit from the system in the event of overheating and with a flame-proof connecting cable (80 cm in length), and they are certified for compliance with **EN 54-24:2008** (certificate no. **0068 PD-033/2013**). The **TRX20-V** was designed for use in special systems (railways, underground railways etc.), and in addition to a thermal fuse and a flame-proof connecting cable, it also has a line transformer for insulation up to 4 kV.

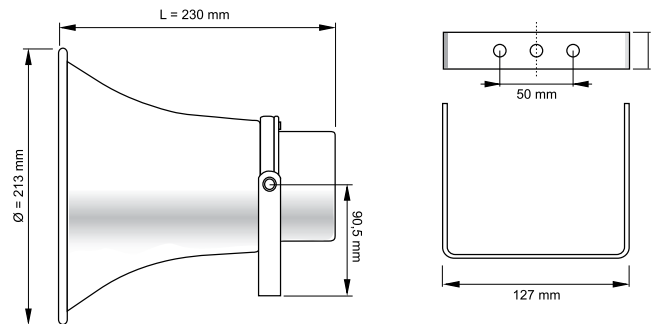

The **TR10-TW** horn-type speaker unit has a die-cast aluminium housing and a stainless steel bracket and screws, while the horn is made of shockproof ABS. It has a driver unit with a line transformer and a rear switch for selecting the operating power (four positions).



TR10-TW

10 W rectangular horn speaker, IP65

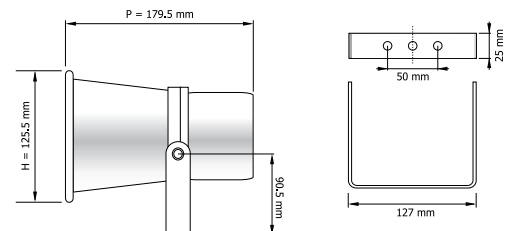

The sealed design (class of protection IP66) and the materials used make the **TR30-TW** speaker unit particularly suitable for use even in unfavourable climatic conditions, in a saline or polluted atmosphere. It has a driver unit with a line transformer and a rear switch for selecting the operating power (five positions).



TR30-TW

30 W round horn speaker, IP66

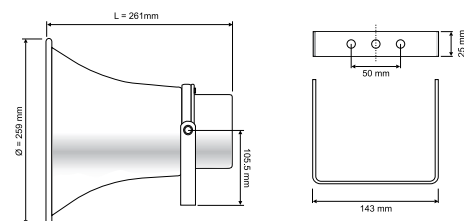

MODEL	TRX20-TW	TRX20-EN	TRX20-V	TR10-TW	TR30-TW
Rated power	20 W			10 W	30 W
Adjustable power	20 / 15 / 10 / 5 / 2,5 W			10 / 5 / 3 / 1 W	30 / 20 / 15 / 10 / 5 W
Characteristics	Die-cast aluminium body, aluminium horn			Die-cast aluminium body, shockproof ABS horn	Aluminium
Loudspeakers	Supplied driver unit				
Sound pressure SPL (P _{nom} /1m)	116 dB			112 dB	122 dB
Efficiency (1W/1m)	103 dB			102 dB	107 dB
Frequency response	500 ÷ 5.000 Hz			450 ÷ 10.000 Hz	350 ÷ 6.000 Hz
Dispersion angle @2kHz	70°			Or. 100° - Ver. 90°	70°
Protection degree	IP 66			IP 65	IP 66
Mounting	Swivelling bracket and connecting cable				
Colour	Light grey				
Dimensions (W x H x D)	Ø 213 x 230 mm			176 x 126 x 180 mm	Ø 259 x 261 mm
Weight	1,8 kg			1,2 kg	1,75 kg



Extended-range two-way horn



TR20-HF 16 W rectangular horn speaker

TR40-HF 40 W rectangular horn speaker



TR30-HF 30 W rectangular horn speaker, IP66

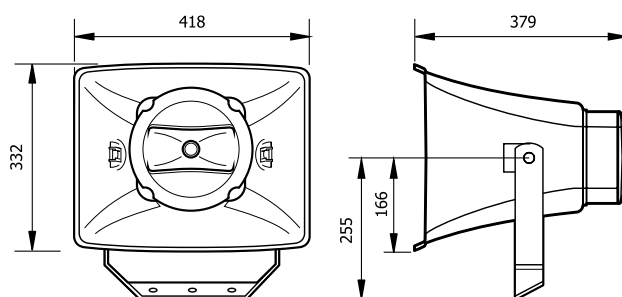
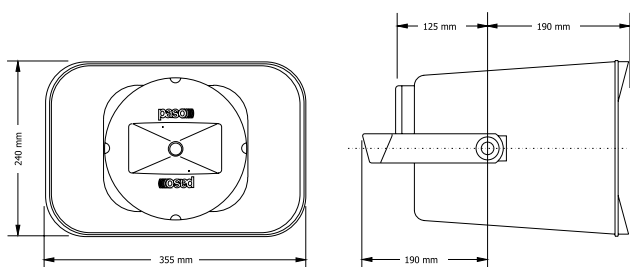

TR20-HF and **TR40-HF** horns are two-way speaker units featuring a high level of efficiency, a wide frequency response range and excellent power-handling capacity. The housing of the speaker unit is made of reinforced polypropylene, self-extinguishing according to UL94-V0. The particular shape of this speaker unit gives rise to practically constant and controlled coverage of the audio spectrum and makes it particularly suitable for any application in which the typical efficiency of horn-type speaker units must be accompanied by a pleasant tone colour and perfect intelligibility. The treble range is reproduced by a horn featuring constant directivity fed by a compression unit for the TR40-HF, and by a dome-type tweeter for the TR20-HF. The medium-bass range is reproduced in both models by a bent horn fed by a cone-shaped loudspeaker (mid-woofer). A cross-over filter separates the frequencies for the two loudspeakers- Thanks to the built-in repeating coil with sockets for adjusting the output power, these speaker units can be connected to constant-voltage sound-distribution lines (100-70-50 V); a 16 Ω connection is also available for low-impedance systems.

The **TR30-HF** horn is a two-way speaker unit featuring high efficiency, a broad response range and good power-handling capacity. The type of construction and the materials used enable it to be used in outdoor applications even in extreme conditions, thanks to the IP66 class of protection. The housing of the speaker unit is made of reinforced polypropylene. The treble range is reproduced by a horn featuring constant directivity fed by a compression unit, while the medium-bass range is reproduced by a bent horn fed by a loudspeaker (mid-woofer) with a cone made of synthetic material. Thanks to the built-in repeating coil with sockets for adjusting the output power, these speaker units can be connected to 100V constant-voltage sound-distribution lines.

MODEL	TR20-HF	TR30-HF	TR40-HF
Rated power	16 W	30 W	40 W
Adjustable power	16 / 8 / 4 W - 16 Ω	30 / 15 / 7,5 / 3,75 W	40 / 20 / 10 / 5 W - 16 Ω
Characteristics	UL94-V0 reinforced polypropylene structure		
Sound pressure SPL (P _{nom} /1m)	116 dB	113 dB	118 dB
Efficiency (1W/1m)	102 dB	98 dB	99 dB
Frequency response	110 ÷ 20.000 Hz	150 ÷ 13.000 Hz	110 ÷ 17.000 Hz
Dispersion angle @2kHz	Or. 45° - Ver. 80°	Or. 35° - Ver. 65°	Or. 45° - Ver. 80°
Protection degree	IP 44	IP 66	IP 44
Mounting	Swivelling bracket and connecting cable		
Colour	White		
Dimensions (W x H x D)	335 x 240 x 315 mm	418 x 332 x 379 mm	335 x 240 x 315 mm
Weight	4,2 kg	5,7 kg	6,2 kg

Exponential horn

With separate driver units

TR1, TR2 and TR3 range

TR3-B Rectangular exponential horn, IP65



TR1-B, TR2-B and **TR3-B** exponential horns are made of grey Moplen. They are unbreakable and weather-proof. Each horn has a swivelling bracket for securing it in place and a rear cap able to contain a **UT35** or **UT60** impedance-type magneto-dynamic unit or a **UT60-T** unit with a 100V transformer, not included in the supply (refer to the appropriate technical table).

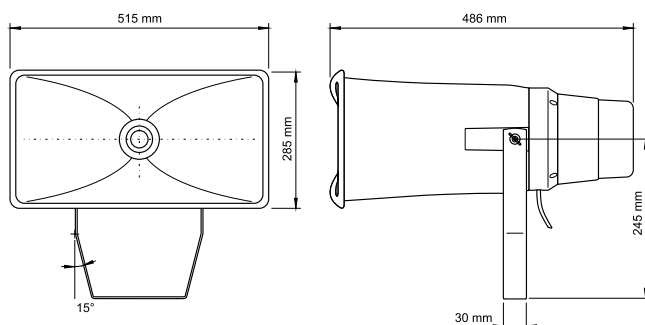

TR2-B Rectangular exponential horn, IP65



TR1-B Round exponential horn, IP65

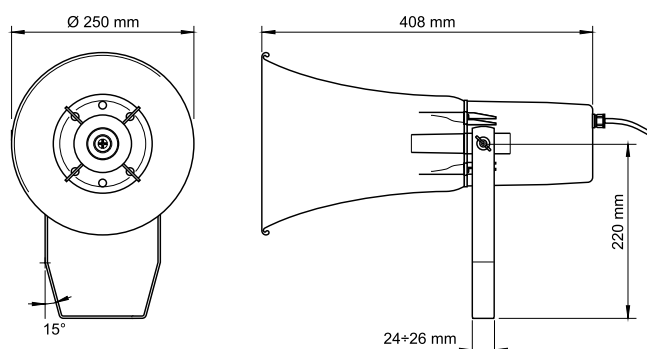
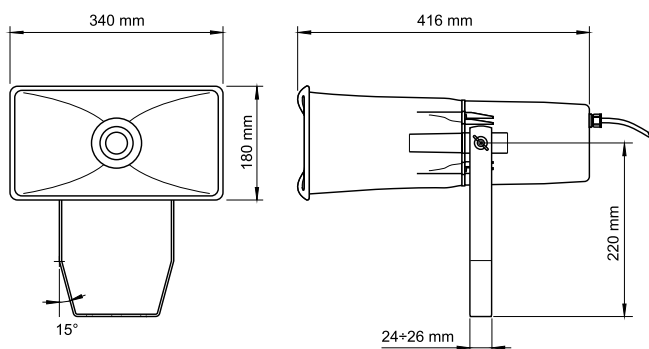

MODEL	TR1-B	TR2-B	TR3-B
Rated power	35 W (UT35/16 Ω), 60 W (UT60-T/100 V)		35 W (UT35/16 Ω), 60 W (UT60/16 Ω), 60 W (UT60-T/100 V)
Characteristics	UV reinforced polypropylene structure		
Sound pressure SPL (P _{nom} /1m)	123 dB (UT35)		125 dB (UT35)
Efficiency (1W/1m)	108 dB (UT35)		110 dB (UT35)
Frequency response	350 ÷ 5000 Hz (UT35)		
Dispersion angle @2kHz	50°	Or. 70° - Ver.50°	Or. 55° - Ver.40°
Protection degree	IP 65		
Mounting	Swivelling bracket		
Colour	Grey		
Dimensions (W x H x D)	Ø 250 x 408 mm	340 x 180 x 416 mm	515 x 285 x 486 mm
Weight	1,2 kg (no driver unit)	1,25 kg (no driver unit)	2,1 kg (no driver unit)



TR400 "SINCRO MIX" range



The **TR400-SX** horn can fit four **UT60** (60 W/16 Ω) or **UT150** (150 W/16 Ω) compression units, supplied separately. The sound waves generated by the single units are synchronised when their acoustic pressure is still in the initial expansion phase. Reinforced fibreglass material. Very high efficiency combined with perfect intelligibility of speech. These features make it particularly suitable for powerful sound broadcasting and/or alarm-signalling systems for airports, motor-racing circuits, horse-racing courses, sports fields, etc.

TR400-SX High-power multiple horn (240 / 600 W)

MODEL	TR400-SX + UT60	TR400-SX + UT150
Rated power	240 W (4x UT60/16 Ω)	600 W (4x UT150/16 Ω)
Characteristics	Reinforced fibreglass structure	
Sound pressure SPL (P _{nom} /1m)	135 dB	141 dB
Efficiency (1W/1m)	112 dB	114 dB
Frequency response	150 ÷ 6.000 Hz	100 ÷ 10.000Hz
Dispersion angle @2kHz	Or. 125° - Ver.150°	
Protection degree	IP 54	
Mounting	Swivelling bracket	
Colour	Grey	
Dimensions (W x H x D)	680 x 410 x 545 mm	
Weight	10 kg (no driver unit)	

Exponential horn driver units

DRIVER UNIT FOR TR1, TR2 AND TR3 RANGE	MODEL	UT35	UT60-T	UT60
	Rated power	35 W / 16 Ω	60 W (60 / 40 / 20 W), with 100 V transformer	60 W / 16 Ω
	Characteristics	For TR1-B / TR2-B / TR3-B		
	Sound pressure SPL (P _{nom} /1m)	124 dB (TR3-B)	128 dB (TR3-B)	127 dB (TR3-B)
	Efficiency (1W/1m)	109 dB (TR3-B)	111 dB (TR3-B)	110 dB (TR3-B)
	Dimensions (W x H x D)	Ø 105 x 106 mm	Ø 112 x 154 mm	Ø 105 x 106 mm
	Weight	1,3 kg	2,1 kg	1,55 kg

DRIVER UNIT FOR TR400-SX RANGE	MODEL	UT60	UT150
	Rated power	60 W, impedance 16 Ω	150 W, impedance 16 Ω
	Characteristics	For TR400-SX	
	Sound pressure SPL (P _{nom} /1m)	135 dB (TR400-SX)	141 dB (TR400-SX)
	Efficiency (1W/1m)	112 dB (TR400-SX)	114 dB (TR400-SX)
	Dimensions (W x H x D)	Ø 105 x 106 mm	Ø 116 x 100 mm
	Weight	1,55 kg	3,1 kg

Ceiling mounting

C57 e C58 range

C58/6-TB 6 W, Ø 220 mm

C58/12-TB 12 W, Ø 220 mm



C57-TB 6 W, Ø 180 mm

The **C57** and **C58** ranges of speaker units for installation in false ceilings guarantee excellent reproduction of both speech and music. They are made of moulded sheet metal treated with white scratchproof and non-reflecting paint and will fit elegantly into any environment.

Each unit consists of a load-bearing ring with spring-operated quick-fit hooks for easy securing to the ceiling. The central mask with the loudspeaker cabled to the line transformer fits into the ring by rotating it until it locks into place. It is possible to apply an optional flameproof cap to protect the unit: **AC957** for the C57-TB or **AC958** for the C58/6-TB and C58/12-TB.

ACCESSORIES

AC957 Flame-proof cap for C57 range

AC958 Flame-proof cap for C58 range

C57-EN and C58-EN range

C57/6-EN and **C58/12-EN** speaker units for installing in false ceilings ensure excellent reproduction of both speech and music. Made of moulded sheet metal treated with white scratchproof and non-reflecting paint, they will fit elegantly into any environment. Each unit consists of a load-bearing ring with spring-operated quick-fit hooks for easy securing to the ceiling.

The central mask with the loudspeaker cabled to the line transformer fits into the ring by rotating it until it locks into place. In accordance with **EN 54-24**, each unit has a galvanised steel flameproof cap, a ceramic terminal block for the connections, a thermal fuse and a terminal for correct connection to earth.



C57/6-EN 6 W, Ø 180 mm

C58/12-EN 12 W, Ø 220 mm

MODEL	C57/6-EN	C58/12-EN	C57-TB	C58/6-TB	C58/12-TB
Rated power	6 W	12 W	6 W		12 W
Adjustable power	6 / 3 / 1,5 W	12 / 6 / 3 W	6 / 3 / 1,5 W		12 / 6 / 3 W
Characteristics	Metal structure				
Loudspeakers	1 two-cone broadband				
Sound pressure SPL (P _{nom} /1m)	99 dB	105 dB	102 dB		105 dB
Efficiency (1W/1m)	92 dB		95 dB		
Frequency response	100 ÷ 15.000 Hz	80 ÷ 20.000 Hz	100 - 15.000 Hz	80 ÷ 20.000 Hz	
Dispersion angle @2kHz	150°	130°	150°	130°	
Mounting	Spring fixing system				
Mounting hole	Ø 160 ÷ 165 mm	Ø 200 ÷ 205 mm	Ø 160 ÷ 165 mm	Ø 200 ÷ 205 mm	
Colour	White				
Dimensions (W x H x D)	Ø 180 x 120 mm	Ø 220 x 140 mm	Ø 180 x 110 mm	Ø 220 x 130 mm	
Weight	1,5 kg	1,7 kg	1,1 kg	1,3 kg	1,45 kg



X-ABT-S136



The **X-ABT-S136** unit for ceiling mounting is suitable for applications in which compact dimensions and top-quality sound are required. This product is the result of state-of-the-art technology and combines a pleasant appearance with excellent sound-performance parameters as well as excellent resistance to mechanical damage and to changing weather conditions. It is also easy to install rapidly. This unit for ceiling mounting has a flameproof cap, a thermal fuse and a double ceramic terminal block (IN/OUT), and a steel safety cable is included in the supply. In order to ensure conformity with the highest quality standards, this speaker unit has been tested using thorough procedures requiring high sound-emission parameters, safety and reliability. The X-ABT-S136 unit for ceiling mounting has been designed to achieve the highest levels of reliability in case of fire and its specifications are such that it can be used with excellent results in any type of public environment.

X-ABT-S136 6 W, metal, Ø 115 mm

X-ABT-S2010

The **X-ABT-S2010** unit for ceiling mounting is the result of state-of-the-art technology and combines a pleasant appearance with excellent sound-performance parameters as well as excellent resistance to mechanical damage and to changing weather conditions. It is also easy to install rapidly. This unit for ceiling mounting has a flameproof cap, a thermal fuse and a double ceramic terminal block (IN/OUT), and a steel safety cable is included in the supply. In order to ensure conformity with the highest quality standards, this speaker unit has been tested using thorough procedures requiring high sound-emission parameters, safety and reliability. The X-ABT-S136 unit for ceiling mounting has been designed to achieve the highest levels of reliability in case of fire and its specifications are such that it can be used with excellent results in any type of public environment.

X-ABT-S2010 10 W, metal, Ø 170 mm



MODEL	X-ABT-S136	X-ABT-S2010
Rated power	6 W	10 W
Adjustable power	6 / 3 / 1,5 / 0,75 W	10 / 5 / 2,5 / 1,25 W
Impedance	1667 Ω, 3333 Ω, 6667 Ω, 13333 Ω	1000 Ω, 2000 Ω, 4000 Ω, 8000 Ω
Sound pressure SPL (Pnom/1m)	90 dB	104 dB
Efficiency (1W/1m)	82 dB	96 dB
Frequency response	60 ÷ 20.000 Hz	150 ÷ 20.000 Hz
Dispersion angle @2kHz	131° / 76°	109° / 80°
Protection degree	IP 32	
Characteristics	Metal structure	
Colour	White (RAL 9003)	
Dimensions (W x H x D)	Ø 135 x 115 mm	Ø 200 x 110 mm
Mounting hole	Ø 115 mm	Ø 170 mm
Weight	0,9 kg	1,5 kg

Ceiling mounting

C51 range



The speaker units for ceiling-mounting of the **C51** range consist of an ABS structure with a RAL 9016 white-painted grille. They feature a compact size and an excellent acoustic performance. Each unit has handy tough spring-type hooks that make it easy to fasten securely to a false ceiling. A transformer for connection to a 100V constant-voltage line is included in the supply, with selectable power-output steps.

C51/6-T 6 W, ABS, Ø 175 mm

C52 range



The speaker units for flush-mounting of the **C52** range are designed specifically for quick installation in false-ceiling panels. They are made of moulded sheet metal with an extremely thin front part. They are ideal for reproduction of both speech and music and are suitable for installation in conference halls, shops and offices. They have strong and handy spring-type hooks making them easy to secure quickly to a false ceiling. Each loudspeaker has a transformer for connection to a 100 V constant-voltage line. The various selectable power steps provide flexibility of installation and the ability to adapt to the acoustic characteristics of different types of room.

C52/6-T 6 W, metal, Ø 200 mm

C52/12-T 12 W, metal, Ø 200 mm

C53 range



The units for ceiling mounting of the **C53** range, designed for easy and quick installation in a false ceiling by means of handy spring-type hooks, are made of moulded sheet metal with an extremely thin front part. Their size and the high quality of the loudspeaker used make it ideal for the reproduction of speech and music and suitable for installation in conference halls and medium-to-large shops and offices. A transformer for connection to a 100V constant-voltage line with selectable power-output steps is included in the supply.

C53/10-T 10 W, metal, Ø 265 mm

MODEL	C52/6-T	C52/12-T	C53/10-T	C51/6-T
Rated power	6 W	12 W	10 W	6 W
Adjustable power	6 / 3 / 1,5 W	12 / 6 / 3 W	10 / 5 / 2,5 W	6 / 3 W
Characteristics	Metal structure			ABS structure, metal front grille
Loudspeakers	1 two-cone broadband			
Sound pressure SPL (P _{nom} /1m)	99 dB	102 dB	103 dB	100 dB
Efficiency (1W/1m)	92 dB		93 dB	
Frequency response	80 ÷ 15.000 Hz		70 ÷ 20.000 Hz	100 ÷ 15.000 Hz
Dispersion angle @2kHz	160°		80°	150°
Mounting hole	Ø 160 ÷ 165 mm		Ø 230 mm	Ø 150 mm
Colour	White			White (RAL 9016)
Dimensions (W x H x D)	Ø 200 x 62 mm		Ø 265 x 79 mm	Ø 175 x 60 mm
Weight	0,64 kg	0,7 kg	1,2 kg	0,5 kg



C47 range



C47/6-TB 6 W, ABS, Ø 140 mm

C47/12-TW 12 W, ABS, for damp environments, Ø 140 mm

The units for ceiling mounting of the **C47** range are characterised by their compact size, excellent acoustic performance and peculiar spring-type system for rapid installation. The **C47/6-TB** is suitable for indoor installations, while the **C47/12-TW** is recommended for particularly damp places (bathrooms, kitchens, swimming pools, shelters and so on). Each unit is made of white self-extinguishing material according to UL94-V0 and has a transformer for connection to constant-voltage lines 100 V with selectable power steps.

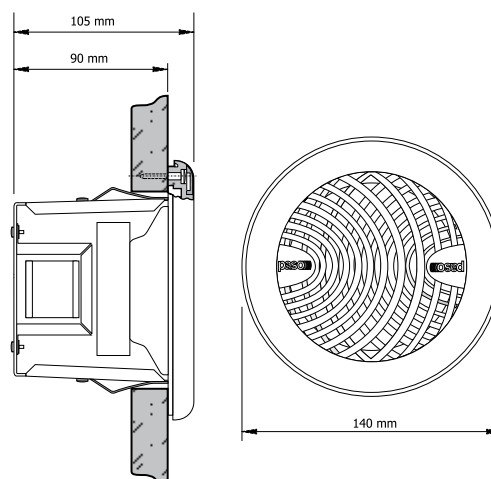

C49 range

Speaker units for protruded ceiling-mounting made of white self-extinguishing ABS according to UL94-V0; these units are recommended for all covered places when excellent sound reproduction with an interesting price/quality ratio is required. They can be combined with C47 units for flush mounting and with projectors of the C48 range which have a matching appearance from the front.

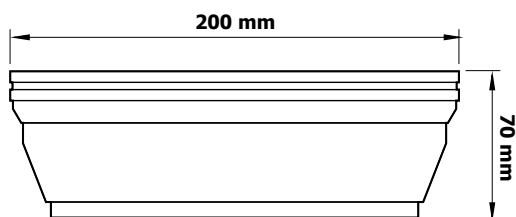

C49/6-T 6 W, ABS protruding speaker, Ø 140 mm

MODEL	C47/6-TB	C47/12-TW	C49/6-T
Rated power	6 W	12 W	6 W
Adjustable power	6 / 3 / 1,5 W	12 / 6 / 3 W	6 / 3 / 1,5 W
Characteristics	UL94-V0 ABS structure		
Loudspeakers	1 broadband		
Sound pressure SPL (Pnom/1m)	97 dB	99 dB	97 dB
Efficiency (1W/1m)	89 dB	88 dB	89 dB
Frequency response	110 ÷ 12.000 Hz	110 ÷ 14.000 Hz	110 ÷ 12.000 Hz
Dispersion angle @2kHz	160°		
Mounting hole	Ø 109 mm		-
Colour	White		
Dimensions (W x H x D)	Ø 140 x 105 mm		Ø 200 x 71 mm
Weight	0,75 kg	0,95 kg	1,2 kg

Ceiling mounting

CSPOT range • "SPOT LIGHT" ceiling-mounting

CSPOT/6-T 6 W, white Ø 105 mm



CSPOT/6-TN 6 W, black, Ø 105 mm



CSPOT/6-TS 6 W, silver, Ø 105 mm



CSPOT ceiling-mounting units are designed specifically to meet the aesthetic requirements of modern interior design.

The small size and the shape of the structure of this speaker unit meet the need to camouflage the presence of the loudspeaker among the decorative and/or functional elements of the ceiling, e.g. flush-mounted lighting fixtures. The structure is made of painted metal, making it a tough product with fine construction details.

The loudspeaker features an excellent performance in spite of the fact that it is smaller than the usual units for ceiling mounting. Installation in false ceilings is simple and rapidly accomplished thanks to the spring-type hooks. The built-in transformer enables connection to constant-voltage lines with adjustable power. The models of the CSPOT range are available in several different colours.

C470 range

The speaker units of the **C470** range for installation in false ceilings are white, with an ABS housing and metal protecting grille. The simple and discreet design and good reproduction of both speech and music enable it to fit perfectly into any architectural environment. The simple spring-type fixing system makes installation quick. The built-in transformer enables it to be connected to constant-voltage lines with variable power.



C470/6-TW 6 W, ABS, IP55, Ø 140 mm

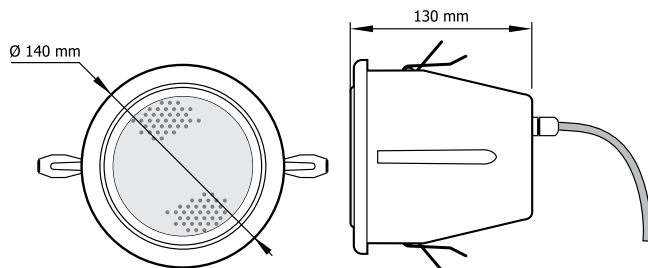

The speaker units of the C470 range are characterised by their compact size and their sealed structure. They are recommended for particularly damp places. They have an ABS rear part, a sealed cable gland and a connecting cable made up of several leads.

MODEL	CSPOT/6-T	CSPOT/6-TN	CSPOT/6-TS	C470/6-TW
Rated power	6 W			
Adjustable power	6 / 4 / 2 W			6 / 3 W
Characteristics	Metal structure			ABS housing, metal front grille
Loudspeakers	1 broadband			
Sound pressure SPL (P _{nom} /1m)	95 dB			98 dB
Efficiency (1W/1m)	86 dB			91 dB
Frequency response	100 ÷ 20.000 Hz			150 ÷ 18.000 Hz
Dispersion angle @2kHz	130°			160°
Protection degree	-			IP 55
Mounting hole	Ø 85			Ø 125 mm
Colour	White	Black	Silver	White
Dimensions (W x H x D)	Ø 105 x 85mm			Ø 140 x 130 mm
Weight	0,5 Kg			0,9 kg



C58-HF range



This is a high-quality and high-power two-way speaker unit for ceiling mounting. It has a white ABS structure with a rear cap and a quick-fitting securing system with hooks. It has all the features required for use in fixed installation and provides high intelligibility of speech and powerful and natural reproduction of music.

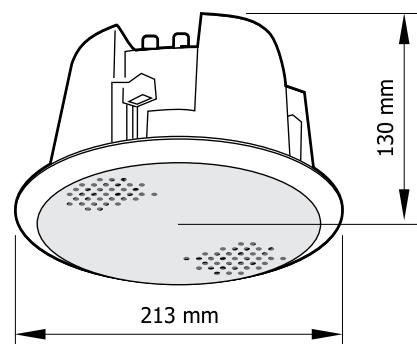

C58/20-HF 20 W, two-way, ABS, Ø 213 mm

C59 range • Pendant speakers

The spherical speaker units of the **C59** range, characterised by an excellent frequency response and ease of use, are suitable for use also in environments that are particularly difficult from the acoustic and plant engineering points of view. They are designed for suspended installation, meeting the requirements of quality sound broadcasting even in large rooms with high ceilings.

These elegant and discreet units feature a white ABS structure and are equipped with constant-voltage line transformers with adjustable power plus devices for securing to the ceiling and a 4 m cable.

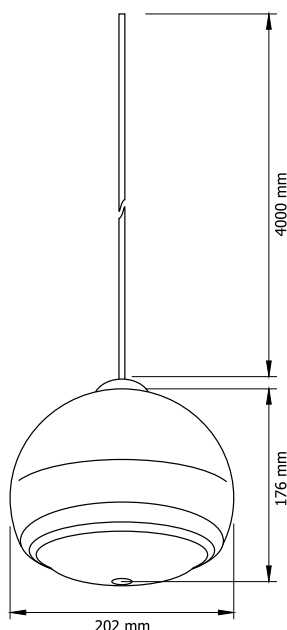

C59-T 15 W ABS spherical speaker

MODEL	C59-T	C58/20-HF
Rated power	15 W	20 W
Adjustable power	15 / 7,5 / 3,75 W	20 W
Characteristics	ABS housing	ABS housing
Loudspeakers	1 broadband	1 Wf + 1 Tw
Sound pressure SPL (Pnom/1m)	100 dB	101 dB
Efficiency (1W/1m)	90 dB	88 dB
Frequency response	70 ÷ 20.000 Hz	80 ÷ 20.000 Hz
Dispersion angle @2kHz	80°	180°
Protection degree	IP 44	-
Mounting	Device for securing to the ceiling and a 4 m cable	Ø 170 mm
Colour	White	
Dimensions (W x H x D)	Ø 202 x 176 mm	Ø 213 x 130 mm
Weight	1,8 Kg	1,4 kg

Accessories for speakers

Transformer-type attenuators • "EUROPA" range

These attenuators enable the sound level in a room to be adjusted by attenuating the sound performance of the speaker units with a transformer in constant-voltage systems (100, 70, 50 V). Each attenuator has an autotransformer, an 11-position switch (10 positions + Off) and front masks. They are available with different output powers, depending on the load that can be connected to them.

Each model (**TL10-RE**, **TL30-RE** and **TL60-RE**) has a by-pass relay able to exclude the attenuator in case of an alarm and/or emergency signal having priority (activation of the relay with a 24 VDC current on an additional two-pole line). They can be easily flush-mounted on a wall using the **AC911** box or secured to a wall using the **AC913** adaptor.



TL10-RE 10 W attenuator with by-pass relay

TL30-RE 30 W attenuator with by-pass relay

TL60-RE 60 W attenuator with by-pass relay

ACCESSORIES FOR ATTENUATORS OF THE "EUROPA" RANGE

AC911 Plastic box for flush-mounting. Size (L x H x P): 70 x 70 x 50 mm

AC913 Plastic adaptor for protruding wall-mounting. Size (L x H x P): 80 x 80 x 50 mm

MODEL	TL10-RE	TL30-RE	TL60-RE
Rated power	10 W	30 W	60 W
Attenuation positions	10 + off		
Attenuation per step	3 dB		
Total attenuation	33 dB		
Override command	24 Vdc		
Characteristics	ABS structure		
Flush-mounting box	AC911 (70 x 70 x 50 mm)		
Wall-mounting box	AC913 (80 x 80 x 50 mm)		
Colour	White		
Dimensions (W x H x D)	80 x 80 x 67 mm		
Weight	220 g	260 g	320 g

TLS60-RE • Selector switch for constant-voltage lines

The **TLS60-RE** selector switch enables selection of six different programmes from constant-voltage lines, directing them to one or more loudspeakers. It also has a 60 W attenuator with a by-pass relay capable of excluding the attenuator in case of an alarm and/or emergency signal having priority (activation of the relay by means of a 24 VDC current on an additional two-pole line). It can be wall-mounted using the **AC914** box.



TLS60-RE 6-line selector switch, 60 W attenuator and by-pass relay

MODEL	TLS60-RE	
SECTION	Attenuator unit	Selector unit
Rated power	60 W	
Attenuation positions	10 + off	6
Attenuation per step	3 dB	-
Total attenuation	33 dB	-
Override command	24 Vdc	
Characteristics	ABS structure	
Wall-mounting box	AC914 (80 x 155 x 50 mm)	
Colour	White	
Dimensions (W x H x D)	80 x 155 x 67 mm	
Weight	425 g	

ACCESSORIES FOR ATTENUATORS OF THE "EUROPA" RANGE

AC914 Plastic adaptor for protruding wall-mounting

Dimensions (W x H x D): 80 x 155 x 50 mm



P8056 • 6-zone multiple attenuator



The **P8056** is a multiple volume control for 50, 70 and 100 V constant-voltage lines, suitable for rack mounting (1 modular unit). It consists of 6 inductive attenuators with 11 positions each (10 + Off), and each of which can bear a maximum load of 50 W. The six output lines (zones) can be split up into two groups of three each so as to drive them with one amplifier or two separate ones. Each attenuator has a bypass relay for sending out announcements and messages without any attenuation. Each relay requires a 24 VDC power supply, with absorption of 10 mA. The rear terminal blocks are of the removable type with slide-type fixtures.

FUNCTIONAL FEATURES

- Six 50-W attenuators
- 6 output lines separable into two groups of three each
- 2 inputs for constant-voltage lines (one for outputs 1, 2 and 3 and the other for outputs 4, 5 and 6)
- One bypass relay for each attenuator
- Can be mounted in a standard 19" rack (height: 1 U)



MODEL	P8056
Attenuator units and output lines	6
Inputs	2 (IN A for outputs 1-2-3, IN B for outputs 4-5-6)
Attenuator rated power	50 W
Attenuation positions	10 + off
Override command	24 Vdc
19" rack mounting (modular units)	Direct (1 U)
Dimensions (W x H x D)	482 x 44 x 150 mm
Weight	4 kg

AC950/20 • Ceramic terminal block with thermal fuse (kit containing 20 off)



Kit for connecting speaker units to bring the installation in line with the standards for voice alarms in those cases in which the whole loudspeaker circuit needs to be safeguarded when one or more speaker units are damaged by fire.

The kit consists of 20 ceramic terminal blocks for connections, able to withstand temperatures exceeding 650°C and fitted with 150°C thermal fuses for cutting the loudspeaker off from the main line in the event of fire.

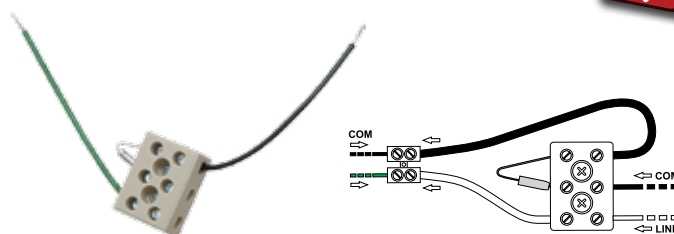

Constant voltage line transformers

TM99-I Trasformer 50-70-100 V, 4-8 Ohm, 6-3-1,5 W

TM104-I Trasformer 50-70-100 V, 4-8 Ohm, 4-2-1 W

TM106-I Trasformer 50-70-100 V, 8 Ohm, 80-40-20 W

Code	Page
0 ÷ 9	
27/59	50
27/901	23
31/2 -100	51
31/65-250	51
31/84-100	51
31/142-100	51
A	
AC14-B	51
AC50	27 29 32
AC50/3	39
AC51	27
AC52	27
AC54-D	27
AC700	49
AC850	50
AC852	50
AC855	50
AC901	57
AC911	74
AC913	74
AC914	74
AC915	54
AC941	57
AC950/20	75
AC957	68
AC958	68
AC3500	34
AC3504	34
AC5660	29 32 42
AC5801-D	27
AC6000	30
AC7200	63
AC8506	15
ACIO8136	19
ACMG8136	19
AW25	24
AW25-DIN	24
AW25R-DIN	24
AW5612	32
AW5624	32
AW5648	32
AWF120-HV	36
AWF240-HV	36
AX3504	34
AX3506	34
AX3512	34
AX6120	29

Code	Page
AX6240	29
AXF120-HV	36
AXF240-HV	36
B	
B12	50
B13-N	51
B20-N	51
B53-C	48 49
B60-N	50
B70-N	50
B116-B	51
B160	50
B260	47
B701-MG	48 49
B711/6-G	20 48 49
B711-G	20 48 49
C	
C33/10-T	54
C34-RB	56
C34-TB	56
C36/6-2T	55
C36/6-EN	55
C36/6-T	55
C37/6-EN	56
C41/10-HF	57
C44/6-TB	57
C44/12-EN	57
C44/20-TB	57
C46-TW	59
C47/6-TB	71
C47/12-TW	71
C48/6-2EN	61
C48/12-2TW	61
C48/12-EN	61
C48/12-TW	61
C49/6-T	71
C51/6-T	70
C52/6-T	70
C52/12-T	70
C53/10 -T	70
C55	60
C55-S	60
C55-TW	60
C56/6-T	59
C56/12-TW	59
C57/6-EN	68
C57-TB	68

Code	Page
C58/6-TB	68
C58/12-EN	68
C58/12-TB	68
C58/20-HF	73
C59-T	73
C86/20-2EN	58
C86/20-2TW	58
C86/20-EN	58
C86/20-TW	58
C94/15-T	53
C94/15-TN	53
C94/30-T	53
C94/30-TN	53
C95/20-T	54
C95/20-TN	54
C95/40	54
C95/40-N	54
C95/40-T	54
C95/40-TN	54
C401-B	21
C402-T	62
C420-T	62
C430-T	62
C440-T	62
C450-TW	62
C470/6-TW	72
C7200-EN	63
CR8506-V	9
CSPOT/6-T	72
CSPOT/6-TN	72
CSPOT/6-TS	72
CV15	51
CV24	51
CV27	51
CV28	51
CV33	51
CV37	51
CV2002	51
CV2005	51
CV2010	51
D	
DAG9300	45
DLC9000	45
F	
F5- N	51
F11-C	51

Code	Page
------	------

I

ITC2000-C	21
-----------	----

L

LAC50	37
LACF01	37
LACL10	37
LAL01	37
LALT01	37
LAM50	37
LARX01	37
LASC50	37
LASC100	37
LASFM01	37
LATR50	37
LATR100	37
LAX50	37
LAX200	37
LAX450	37
LAX800	37

M

M1-NC	47
M132-V	16
M936	47
M976	47
MA853/R850A	50
MA855/R850A	50
MC30-GN	51
MC102	47
MC102-N	47
MC132-V	16
MC250	47
MC260	47
MC265	47
MX5539	45

P

P5201-D	27
P5202-D	27
P5203-D	27
P5404-D	26 27
P5408-D	26 27
P5410-D	26 27
P5416-D ÷ P5440-D	26 27
P5712 ÷ P5740	26 27
P5808	26 27
P5812-D ÷ P5840-D	26 27
P8001-B	27

Code	Page
------	------

P8002-M	27
P8003/2-B	27
P8004	27
P8008-D	27
P8011-D	27
P8012-D	27
P8013-D	27
P8014-D	27
P8030	27
P8032	27
P8035	27
P8036	20
P8056	75
P8082	27
P8083	44
P8083-2ALL	44
P8083-2T	44
P8083-ALL	44
P8083-P	44
P8083-R	44
P8083-T	44
P8136	18
P8236	18
PA1060	42
PA1120	42
PA1240	42
PA6120	39
PA6240	39
PA8506-V	14
PMB106-G	16 48 49
PMB112-EG	16 48 49
PMB112-G	16 48 49
PMB132/12-V	16
PMB132-V	16
PMD125-V	10 11
PMD250-V	10 11
PMD500-V	10 11
PMS2001	11

R

RT8506-V	12
----------	----

S

S1	50
S4-B	62
S8	50
S10	50
SDA200	22
SDA200-N	22

Code	Page
------	------

SDA200-T	22
SDA200-TN	22
SDB200	22
SDB200-N	22
SDM200	22
SDP220	22
SDP220-N	22
SDT100	23
SDT101	23

T

TL10-RE	74
TL30-RE	74
TL60-RE	74
TLS60-RE	74
TM99-I	75
TM104-I	75
TM106-I	75
TR1-B	66
TR2-B	66
TR3-B	66
TR10-TW	64
TR20-HF	65
TR30-HF	65
TR30-TW	64
TR40-HF	65
TR400-SX	67
TRX20-EN	64
TRX20-TW	64
TRX20-V	64

U

UT35	67
UT60	67
UT60-T	67
UT150	67

W

W-MS24/4	17
W-MS24/40	17
W-MS24/150	17
W-MS24/WF	17

X

X-ABT-S136	69
X-ABT-S2010	69

Always staying ahead!

PASO constantly strives to improve its product range and provide exclusive services. The technical up-dates to PASO's systems and all the sales novelties are available at www.paso.it and now also at www.facebook.com/paso.it



This new **catalogue** which includes totally innovative product lines, is intended to mark the Company's constant commitment. It is a useful tool for designing and creating sound amplification and conference systems for small and medium-sized applications. **PASO** also offers complete solutions for audio systems applied to emergency services and congress systems. For further information, please visit **www.paso.it**.

Sound broadcasting system

Sound-broadcasting installations, especially if they are complex and require high levels of safety and flexibility, must be combined increasingly frequently with sophisticated systems for managing and controlling the various components, for flexible selection of the inputs and outputs and for interfacing with external peripheral equipment. For these and other demanding applications, **PASO** offers several solutions such as, by way of example, the master/slave multizone units (P8136/P8236), an extremely versatile professional voice/music distribution "system" capable of meeting the most complex system specifications.

Voice Evacuation Systems (VES)

On premises featuring the presence of large numbers of people, it is essential to have a suitable sound-broadcasting system that, activated by the fire alarm control unit, is able to manage emergency situations, enabling guided and controlled evacuation of the building. The European standards now in force define specifically the design and installation terms required in order to meet the appropriate safety and reliability requirements. **PASO** can offer solutions that comply in full with the voice evacuation and safety standards (EN 54-16, EN 60849).

Congress systems

The secret of a successful conference depends on the use of congress systems able to guarantee clear and intelligible speech, together with evolved management tools enabling the use of advanced information and multimedia services. The **CS2000** and **AULA** conference systems are able to meet these requirements in a simply and orderly manner, offering an elegant solution "Made in Italy".



www.paso.it

ED. 01/2014

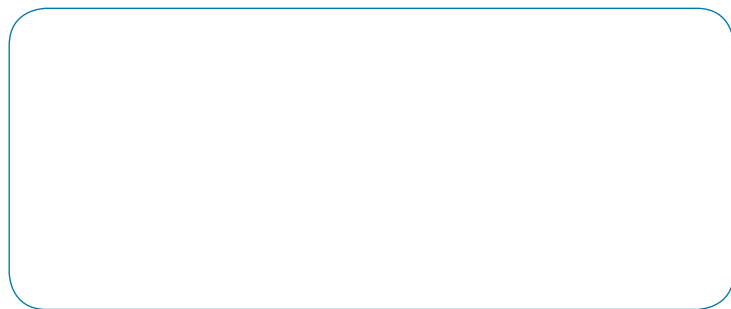

Detailed technical data sheets, operation diagrams and user manuals of the main products are available at www.paso.it

PASO S.p.A. strive to improve their products continuously, and therefore reserve the right to make changes to the drawings and technical specifications at any time and without notice.



Download a QR-reader application to your smartphone free of charge and scan the QR code shown opposite with the camera. You will enter in the **PASO** world immediately.



09/ 80- E



PASO S.p.A.

Via Settembrini, 34 - 20020 Lainate (MI) / ITALY
Phone: +39.0258077.1 - Fax: +39.0258077.277
info@paso.it - www.paso.it